

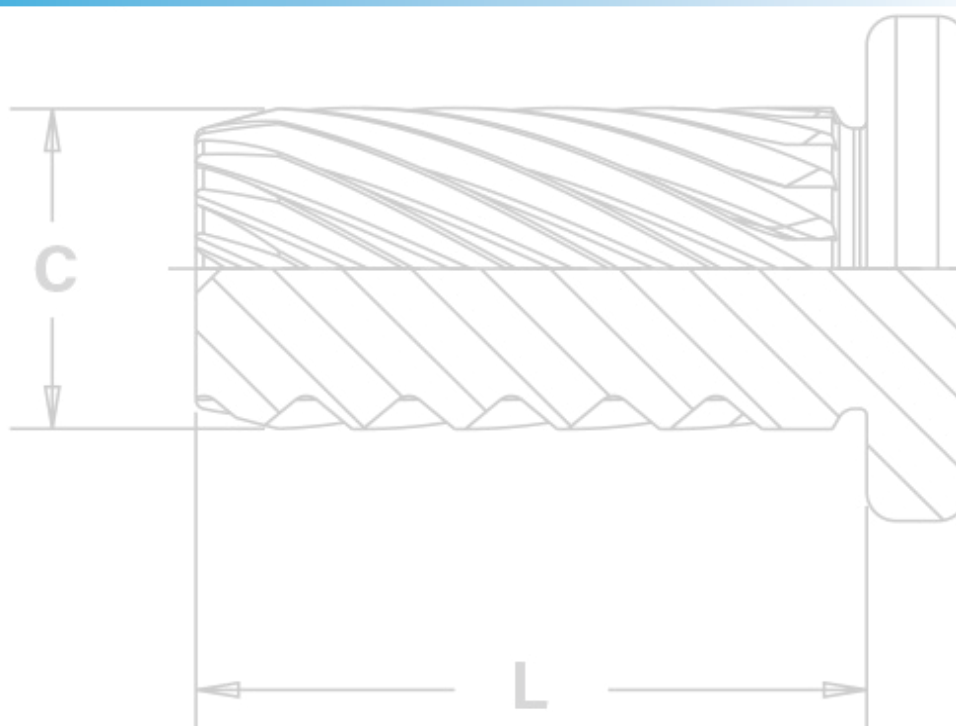

For attachment of thin panels to
plastics, common casting materials
and other similar materials.

TK™

TACKSERT® PINS



For attachment of thin sheets to plastics, common casting materials and other similar base materials.

- Secure sheets to common magnesium die casting materials such as AZ91D. Also appropriate for attaching panels to plastics such as ABS.
- Alternative to screws, eliminating the need to tap or use threaded inserts.
- Tapered tip for easier alignment into base panel.
- Top sheet can be any material.
- Low-profile head.
- Simple, press-in installation. Does not require heat or ultrasonics.
- Can be installed automatically.

TK4™ TackSert® pins



PART NUMBER DESIGNATION

TK4 - **25** - **500**

↓ ↓ ↓

Type & Material Base Panel Hole Size Code Length Code

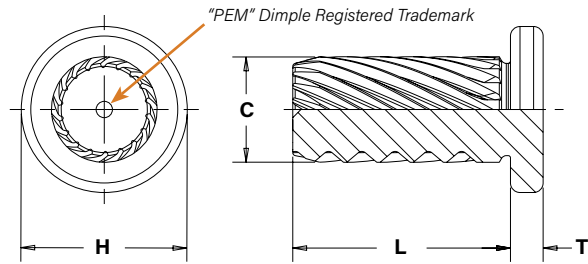
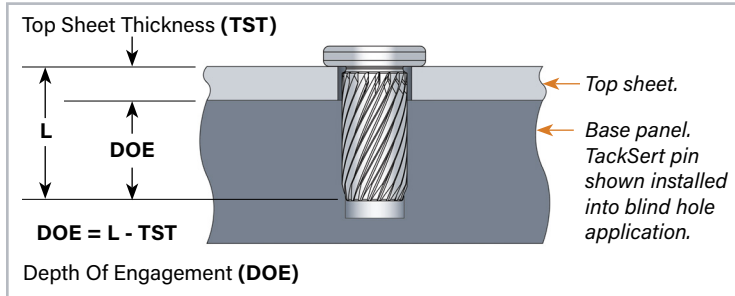

For through hole applications

Min. Base Panel Thickness = DOE - 1 mm / .039" (1)

For blind hole applications

Min. Blind Hole Depth = DOE + 0.8 mm / .032"

Type	Base Panel Hole Size Code	Length Code	Top Sheet Hole Size		Base Panel Hole Size		Top Sheet Thickness Max.		C Max.		H		L		T		Min. Dist. Hole To Edge (2)	
			±0.12 mm/±.005"	mm	in.	mm	in.	mm	in.	mm	in.	mm	in.	mm	in.	mm	in.	mm
TK4	25	500	3.13	.123	2.5	.098	2.2	.087	2.88	.113	4.4	.173	5	.197	0.8	.032	3	.118
TK4	25	600	3.13	.123	2.5	.098	2.6	.102	2.88	.113	4.4	.173	6	.236	0.8	.032	3	.118
TK4	25	800	3.13	.123	2.5	.098	3.4	.134	2.88	.113	4.4	.173	8	.315	0.8	.032	3	.118
TK4	25	1000	3.13	.123	2.5	.098	4.2	.165	2.88	.113	4.4	.173	10	.394	0.8	.032	3	.118
TK4	30	500	3.7	.146	3	.118	1.7	.067	3.4	.134	5.2	.205	5	.197	1	.040	3.5	.138
TK4	30	600	3.7	.146	3	.118	2	.079	3.4	.134	5.2	.205	6	.236	1	.040	3.5	.138
TK4	30	800	3.7	.146	3	.118	2.5	.098	3.4	.134	5.2	.205	8	.315	1	.040	3.5	.138
TK4	30	1000	3.7	.146	3	.118	3.1	.122	3.4	.134	5.2	.205	10	.394	1	.040	3.5	.138
TK4	35	600	4.27	.168	3.5	.138	2.2	.087	3.92	.154	6.1	.240	6	.236	1.2	.047	4	.157
TK4	35	800	4.27	.168	3.5	.138	2.8	.110	3.92	.154	6.1	.240	8	.315	1.2	.047	4	.157
TK4	35	1000	4.27	.168	3.5	.138	3.4	.134	3.92	.154	6.1	.240	10	.394	1.2	.047	4	.157
TK4	35	1200	4.27	.168	3.5	.138	4	.158	3.92	.154	6.1	.240	12	.472	1.2	.047	4	.157
TK4	40	600	4.84	.191	4	.158	1.7	.067	4.44	.175	7	.276	6	.236	1.4	.055	4.5	.177
TK4	40	800	4.84	.191	4	.158	2.1	.083	4.44	.175	7	.276	8	.315	1.4	.055	4.5	.177
TK4	40	1000	4.84	.191	4	.158	2.5	.098	4.44	.175	7	.276	10	.394	1.4	.055	4.5	.177
TK4	40	1200	4.84	.191	4	.158	2.9	.114	4.44	.175	7	.276	12	.472	1.4	.055	4.5	.177
TK4	50	800	5.98	.236	5	.197	2.7	.106	5.48	.216	8.7	.343	8	.315	1.6	.063	5.6	.221
TK4	50	1000	5.98	.236	5	.197	3.2	.126	5.48	.216	8.7	.343	10	.394	1.6	.063	5.6	.221
TK4	50	1200	5.98	.236	5	.197	3.7	.146	5.48	.216	8.7	.343	12	.472	1.6	.063	5.6	.221
TK4	50	1600	5.98	.236	5	.197	4.7	.185	5.48	.216	8.7	.343	16	.630	1.6	.063	5.6	.221

(1) Min. base panel thickness allows for 1 mm / .039" protrusion. Anvil will require clearance.

(2) As a guideline, minimum boss diameter is twice centerline-to-edge value. Testing this product in your application is recommended.

TKA™/TK4™ microPEM® TackSert® pins

- Ideal for compact electronics.

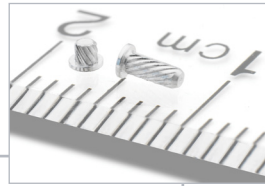

PART NUMBER DESIGNATION

TKA - 10 - 200
TK4 - 10 - 200

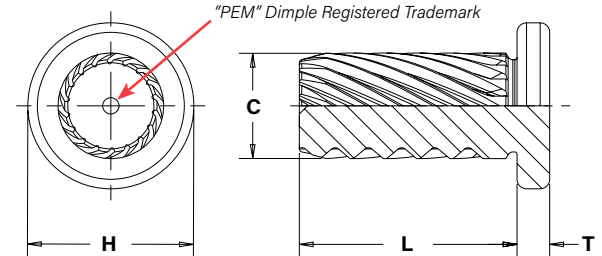
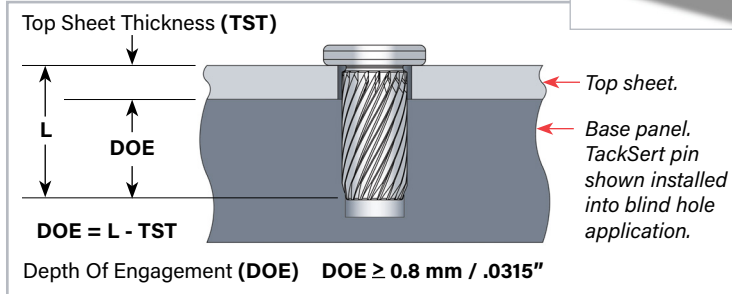
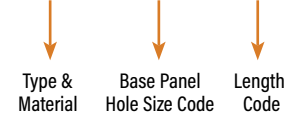

For through hole applications
DOE - 0.25 mm / .010" = Min. Sheet

For blind hole applications
DOE + 0.25 mm / .010" = Min. Blind Hole Depth

Type		Base Panel Hole Size Code	Length Code	Top Sheet Hole Size ±0.05 mm/±.002"		Base Panel Hole Size -0.05 mm/-0.02"		Top Sheet Thickness Max.		C Max.		H ±0.08 mm/±.003"		L ±0.06 mm/±.002"		T ±0.08 mm/±.003"		Min. Dist. Hole To Edge (1)	
Aluminum	400 series stainless steel			mm	in.	mm	in.	mm	in.	mm	in.	mm	in.	mm	in.	mm	in.	mm	in.
TKA	TK4	10	100	1.3	.051	1	.039	0.2	.008	1.2	.047	1.8	.071	1	.039	0.27	.011	1.18	.047
TKA	TK4	10	150	1.3	.051	1	.039	0.7	.028	1.2	.047	1.8	.071	1.5	.059	0.27	.011	1.18	.047
TKA	TK4	10	200	1.3	.051	1	.039	1.2	.047	1.2	.047	1.8	.071	2	.079	0.27	.011	1.18	.047
TKA	TK4	10	250	1.3	.051	1	.039	1.7	.067	1.2	.047	1.8	.071	2.5	.098	0.27	.011	1.18	.047
TKA	TK4	10	300	1.3	.051	1	.039	2.2	.087	1.2	.047	1.8	.071	3	.118	0.27	.011	1.18	.047

(1) Minimum boss diameter is twice centerline-to-edge value.

Comparison of TackSert® pin to screw installation.

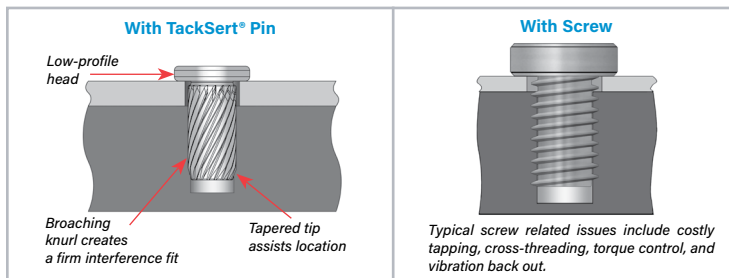

MATERIAL AND FINISH SPECIFICATIONS

Type	Fastener Materials		Standard Finishes		For Use in Sheet Hardness: (1)		
	Hardened 400 Series Stainless Steel	Hardened Aluminum	Passivated and/or Tested per ASTM A380	Plain Finish	PC Board	Plastics	Castings and Brittle Materials
TKA	▪	▪	▪	▪	▪	▪	▪
TK4	▪	▪	▪	▪	▪	▪	▪
Part Number Codes For Finishes			None	None			

(1) HRB - Hardness Rockwell "B" Scale. HB - Hardness Brinell.



INSTALLATION

1. Prepare properly sized mounting hole in top sheet and base panel. Base panel mounting hole can be through or blind.
2. Place top sheet and base panel in proper position.
3. Place pin through hole in top sheet and into mounting hole of base panel.
4. With punch and anvil surfaces parallel, apply squeezing force until the head of the pin contacts the top sheet.

TackSert® pins PEMSERTER® Installation Tooling

Size	Punch Part Number	Anvil Part Number
TK4-25	975200048	975200046
TK4-30		
TK4-35		
TK4-40		
TK4-50		

TK4™ TackSert® pins can be installed automatically in high volume applications. Contact your nearest Engineering representative for more information.

microPEM® TackSert® pins PEMSERTER® Installation Tooling

Size	Punch Part Number	Anvil Part Number
TKA/TK4-10-100	8014167	975200046
TKA/TK4-10-150		
TKA/TK4-10-200		
TKA/TK4-10-250		
TKA/TK4-10-300		

microPEM® TackSert® pins can be installed automatically in high volume applications. Contact your nearest Engineering representative for more information.

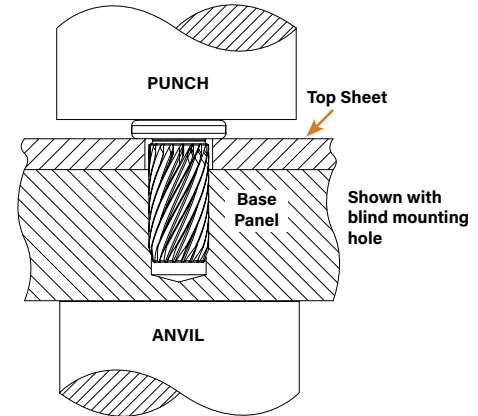

BEFORE PRESSING

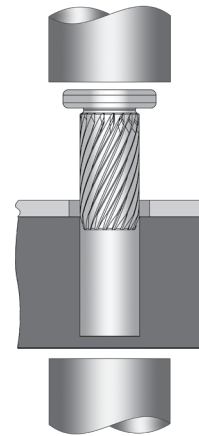

AFTER PRESSING

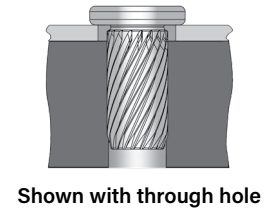

A NOTE ABOUT FASTENERS FOR STAINLESS STEEL PANELS

400 Series fasteners should not be used if the end product: will be exposed to any appreciable corrosive presence, requires non-magnetic fasteners or will be exposed to any temperatures above 300°F (149°C). If any of these are issues, please contact techsupport@pemnet.com for other options.

INSTALLATION NOTES

- For best results we recommend using a HAEGER® or PEMSERTER® machine for installation of PEM® self-clinching fasteners. Please check our website for more information.
- Visit the Animation Library on our website to view the installation process [for select products](#).

PERFORMANCE DATA⁽¹⁾

TK4™ TackSert® pins

Type / Size	Depth of Engagement		Test Base Panel Material											
			ABS				Polycarbonate				Magnesium Casting (AZ91D)			
			Installation		Pullout		Installation		Pullout		Installation		Pullout	
(mm)	(in.)	(N)	(lbs.)	(N)	(lbs.)	(N)	(lbs.)	(N)	(lbs.)	(N)	(lbs.)	(N)	(lbs.)	
TK4-25-500	2.5	.0984	1118	251.5	26.9	6	1800	404.9	53.8	12.1	2700	607.4	221.5	49.8
TK4-25-600	3.1	.1220	1413	317.9	39.2	8.8	2300	517.4	100.3	22.6	3600	809.9	293.8	66.1
TK4-25-800	4.3	.1693	1662	373.9	49.6	11.2	2300	517.4	139.6	31.4	4500	1012.4	354.9	79.8
TK4-25-1000	5.5	.2165	1847	415.5	63.8	14.4	2300	517.4	193.3	43.5	4900	1102.4	438.3	98.6
TK4-30-500	3	.1181	1060	238.5	66.9	15.1	2300	517.4	204.9	46.1	4900	1102.4	456.3	102.7
TK4-30-600	3.7	.1457	1800	404.9	76.2	17.1	2300	517.4	240.1	54	4900	1102.4	510.9	114.9
TK4-30-800	5.2	.2047	1800	404.9	88.5	19.9	2700	607.4	286.3	64.4	5400	1214.8	582.9	131.1
TK4-30-1000	6.6	.2598	2300	517.4	104	23.4	2700	607.4	344.7	77.5	5400	1214.8	673.6	151.5
TK4-35-600	3.5	.1378	1800	404.9	106.9	24.1	2300	517.4	355.9	80.1	5400	1214.8	690.9	155.4
TK4-35-800	4.9	.1929	1800	404.9	116.5	26.2	2300	517.4	392.1	88.2	5400	1214.8	747.2	168.1
TK4-35-1000	6.3	.2480	2700	607.4	138.6	31.2	4100	922.4	475.2	106.9	5800	1304.8	876.4	197.2
TK4-35-1200	7.7	.3031	2700	607.4	156.8	35.3	4500	1012.4	544.1	122.4	5800	1304.8	983.5	221.2
TK4-40-600	4	.1575	2300	517.4	159.5	35.9	3200	719.4	554.2	124.7	5400	1214.8	999.1	224.8
TK4-40-800	5.6	.2205	2300	517.4	183.9	41.4	3200	719.4	646.4	145.4	5800	1304.8	1142.4	257
TK4-40-1000	7.2	.2835	2300	517.4	197.1	44.3	3200	719.4	696.1	156.6	5800	1304.8	1219.7	274.4
TK4-40-1200	8.8	.3465	2300	517.4	212.1	47.7	3200	719.4	752.5	169.3	6700	1507.3	1307.4	294.1
TK4-50-800	5	.1969	3200	719.9	246.5	55.4	3600	709.9	882.3	198.5	5800	1304.8	1509	339.5
TK4-50-1000	6.5	.2559	3200	719.9	264.6	59.5	4100	922.4	950.9	213.9	5800	1304.8	1615.6	363.5
TK4-50-1200	8	.3150	3200	719.9	309	69.5	4100	922.4	1118.2	251.6	6300	1417.3	1875.6	422
TK4-50-1600	11	.4331	3600	809.9	434	97.6	4500	1012.4	1590	357.7	8100	1822.3	2608.9	586.9

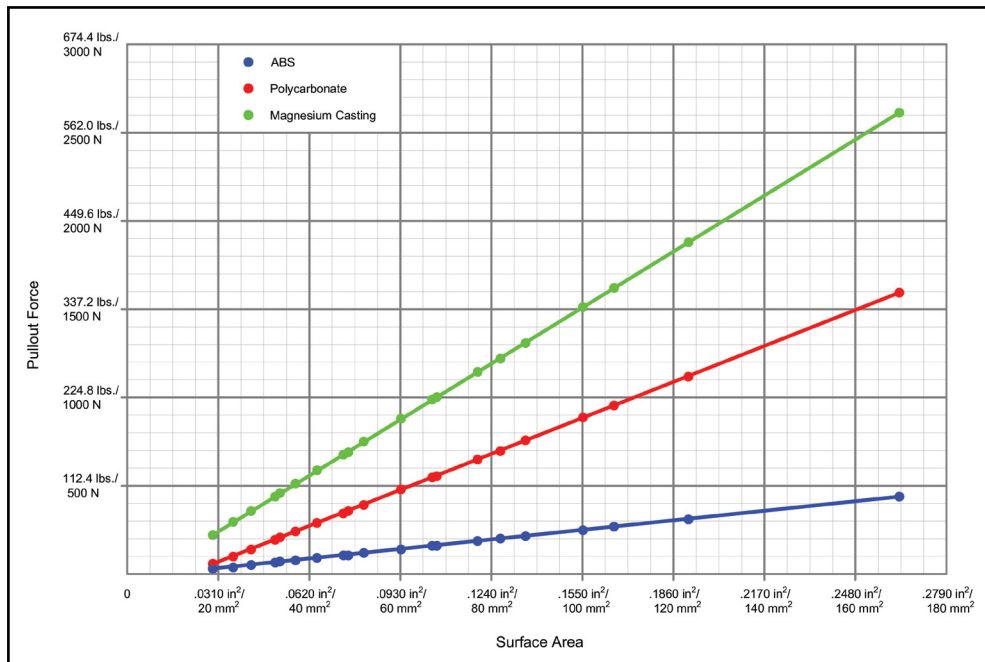

(1) Published installation forces are for general reference. Actual set-up and confirmation of complete installation should be made by observing proper seating of fastener as described in the installation steps. Other performance values reported are averages when all proper installation parameters and procedures are followed. Variations in mounting hole size, sheet material, and installation procedure may affect performance. Performance testing this product in your application is recommended. We will be happy to provide technical assistance and/or samples for this purpose.



PERFORMANCE DATA⁽¹⁾ (Continued)

TKA™/TK4™ microPEM® TackSert® pins

Type	Test Base Panel Material	Depth Of Engagement		Installation		Pullout	
		(mm)	(in.)	(N)	(lbs.)	(N)	(lbs.)
TKA-10	ABS	0.8	0.0315	133	30	9	2
		1	0.0394	133	30	14	3
		1.3	0.0492	133	30	19	4
		1.5	0.0590	178	40	24	6
		1.8	0.0708	178	40	31	7
		2	0.0787	222	50	35	8
		2.3	0.0886	222	50	41	9
TKA-10	Polycarbonate	0.8	0.0315	222	50	25	6
		1	0.0394	267	60	37	8
		1.3	0.0492	267	60	53	12
		1.5	0.0590	311	70	68	15
		1.8	0.0708	334	75	86	19
		2	0.0787	378	85	98	22
		2.3	0.0886	400	90	113	25
TK4-10	Magnesium Casting (AZ91D)	0.8	0.0315	445	100	29	7
		1	0.0394	489	110	43	10
		1.3	0.0492	534	120	61	14
		1.5	0.0590	578	130	78	18
		1.8	0.0708	623	140	99	22
		2	0.0787	667	150	113	25
		2.3	0.0886	712	160	131	29
		2.8	0.1102	801	180	169	38

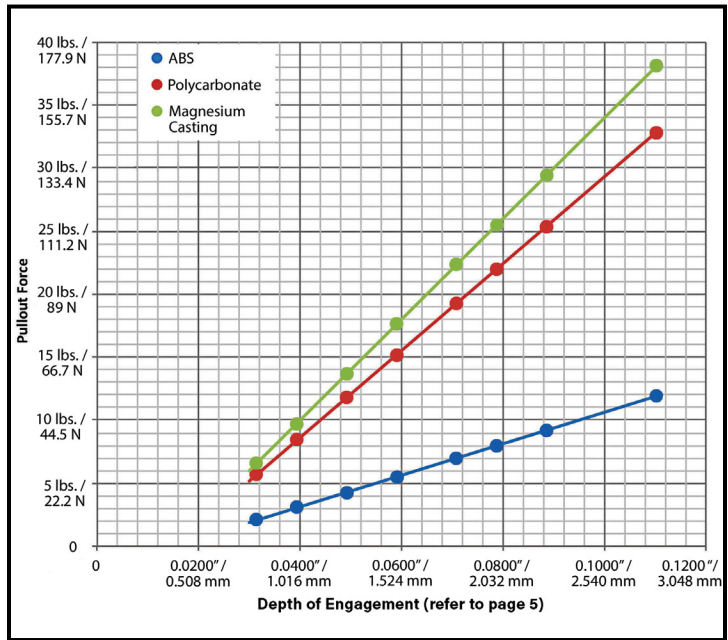

(1) **Published installation forces are for general reference. Actual set-up and confirmation of complete installation should be made by observing proper seating of fastener as described in the installation steps. Other performance values reported are averages when all proper installation parameters and procedures are followed. Variations in mounting hole size, sheet material, and installation procedure may affect performance. Performance testing this product in your application is recommended. We will be happy to provide technical assistance and/or samples for this purpose.**



All PEM® products meet our stringent quality standards. If you require additional industry or other specific [quality certifications](#), special procedures and/or part numbers are required. Please contact your local sales office or representative for further information.

Regulatory [compliance information](#) is available in Technical Support section of our website. Specifications subject to change without notice. See our website for the most current version of this bulletin.

PennEngineering®



North America: Danboro, Pennsylvania USA • E-mail: info@pemnet.com • Tel: +1-215-766-8853 • 800-237-4736 (USA)

Europe: Galway, Ireland • E-mail: europa@pemnet.com • Tel: +353-91-751714

Asia/Pacific: Singapore • E-mail: singapore@pemnet.com • Tel: +65-6-745-0660

Shanghai, China • E-mail: china@pemnet.com • Tel: +86-21-5868-3688

Visit our PEMNET™ Resource Center at www.pemnet.com • Technical support e-mail: techsupport@pemnet.com