

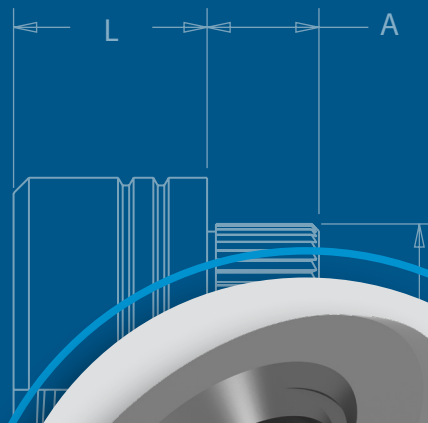

RVTB™

PEM® CAPTIVATED THREADED RIVET BUSHES

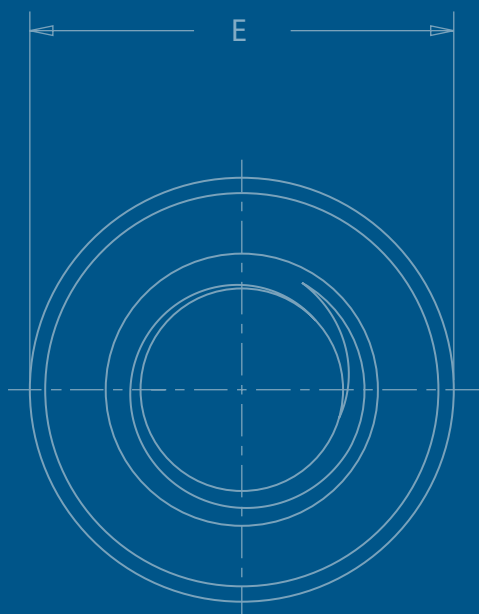

PEM® brand rivet bushes provide strong, permanent, reusable female threads mounted into metal sheets as thin as 0.5 mm

PEM® RVTB™ CAPTIVATED THREADED RIVET BUSHES

High performance fasteners designed for use in sheet metal

PEM® RAB™ and RABS™ round rivet bushes provide strong reusable threads in panels too thin to be tapped. They can be installed into any material hardness in sheets as thin as 0.5 mm, and can be installed closer to the edge with no panel distortion. They can be easily installed on a Haeger® or PEMSERTER® machine and offer high pushout and torque resistance thanks to their serrated shank.

PEM® Type RMAB™ and RMABS™ mini rivet bushes work in the same way as the round type, but have smaller body dimensions for applications where space is restricted.

Both the round and mini style rivet bushes are available in thread sizes from M3 through M5 in mild steel and stainless steel.

Benefits include:

- Torque-resistant and capable of withstanding loads applied from both sides.
- Can be installed into any material hardness.
- Can be installed close to the edge with no panel distortion.
- Can be installed in painted chassis materials.
- High pushout performance.
- Custom designed in a wide range of sizes and profiles
- Can be installed into laminate material and non-ductile materials.

Fastener drawings and models are available at www.pemnet.com.

Custom sizes are available on special order. [Contact us](#) for more information.

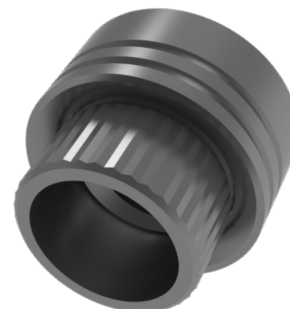

View the [installation animation](#)

View full [product information](#)

RAB™ and RABS™ Round Rivet Bushes

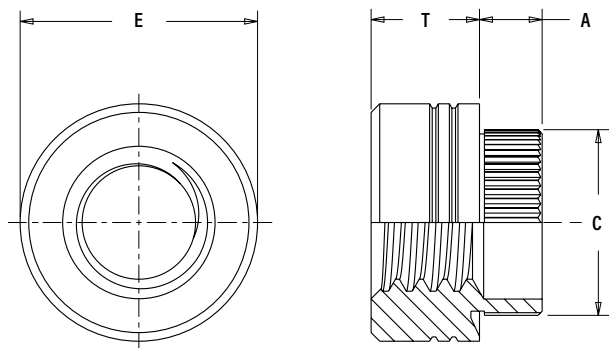

Part Number Designation

RAB - **M3** - **09** **ZI**
RABS - **M3** - **09**

↓ ↓ ↓ ↓
 Type Thread Code Sheet Code Finish

All dimensions are in millimeters.

Metric	Thread Size x Pitch	Type		Thread Code	Sheet Code	Suitable Sheet Thickness	Hole Size in Sheet +0.08	A ±0.1	C Max.	E Nom.	T ±0.1
		Steel	Stainless Steel								
M3 x 0.5	RAB	RABS	M3	09	0.9-1.0	6	1.6	5.98	7.9	3.2	
				11	1.1-1.3		2				
				14	1.4-1.6		2.3				
M4 x 0.7	RAB	RABS	M4	09	0.9-1.0	7	1.7	6.98	9.5	3.8	
				11	1.1-1.3		2				
				14	1.4-1.6		2.3				
M5 x 0.8	RAB	RABS	M5	09	0.9-1.0	8.4	1.7	8.38	11.1	4.4	
				11	1.1-1.3		2				
				14	1.4-1.6		2.4				

RMAB™ and RMABS™ Round Mini Rivet Bushes

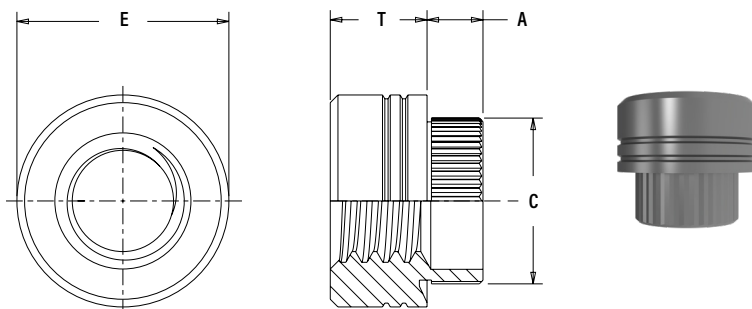

Part Number Designation

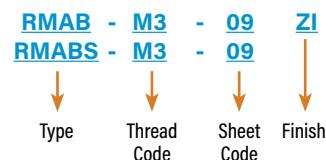

All dimensions are in millimeters.

Metric	Thread Size x Pitch	Type		Thread Code	Sheet Code	Suitable Sheet Thickness	Hole Size in Sheet +0.08	A ±0.1	C Max.	E Nom.	T ±0.1
		Steel	Stainless Steel								
Metric	M3 x 0.5	RMAB	RMABS	M3	09	0.9-1.0	4.2	1.7	4.18	5.5	2.8
					11	1.1-1.3		2			
					14	1.4-1.6		2.3			
	M4 x 0.7	RMAB	RMABS	M4	09	0.9-1.0	5.5	1.7	5.48	7	3.2
					11	1.1-1.3		2			
					14	1.4-1.6		2.3			
M5 x 0.8	RMAB	RMABS	M5	09	0.9-1.0	6.5	1.7	6.48	8.5	3.8	
				11	1.1-1.3		2				
				14	1.4-1.6		2.3				

Material and Finish Specifications

Type	Component Material		Standard Finishes	
	Carbon Steel	300 Series Stainless	Zinc Plated per ASTM B633, SCI (5µm), Type III, Colorless (1)	Passivated and/or Tested per ASTM A380
RAB	▪		▪	
RABS		▪		▪
RMAB	▪		▪	
RMABS		▪		▪
Part Number Code for Finished			ZI	None

(1) See PEM® [Technical Support](#) section of our website for related plating standards and specifications.

Custom sizes are available on special order.
[Contact us](#) for more information.

Installation Tooling

1. Prepare properly sized mounting hole in the sheet. Do not perform any secondary operations such as deburring.
2. Place the shank of the fastener into the mounting hole
3. With the installation punch and anvil surfaces parallel, apply squeezing force to flare the shank of the fastener.

Type	Thread Size	HAEGER® Part Number		PEMSERTER® Part Number	
		Anvil	Punch	Anvil	Punch
RAB/RABS	M3	10-00286	10-00679	8026876	8026875
	M4	10-00288	10-00681	8026878	8026877
	M5	10-00289	10-00682	8026880	8026879
RMAB/RMABS	M3	10-00286	10-00686	8026882	8026881
	M4	10-00288	10-00687	8026884	8026883
	M5	10-00289	10-00688	8026886	8026885

Haeger® Punch Dimensions - RAB™ and RABS™(1)

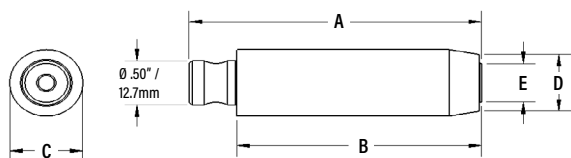

Haeger® Punch Part #	Thread Code	A mm	B mm	Dia. C mm	Dia. D mm	Dia. E mm
10-00679	M3	6.2	63.5	12.7	7.5	4.17
10-00681	M4	76.2	63.5	12.7	8.7	5.13
10-00682	M5	76.2	63.5	12.7	10.3	6.63

Haeger® Punch Dimensions - RMAB™ and RMABS™(1)

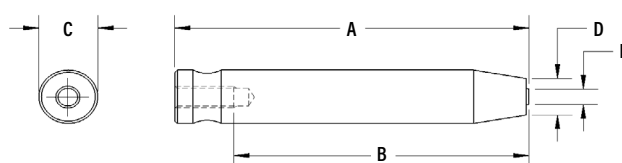

Haeger® Punch Part #	Thread Code	A mm	B mm	Dia. C mm	Dia. D mm	Dia. E mm
10-00686	M3	76.2	63.5	12.7	5.5	3.1
10-00687	M4	76.2	63.5	12.7	7.5	4.3
10-00688	M5	76.2	63.5	12.7	8.7	5.31

(1) The Pin Style Nut Tooling is recommended for use with these tools.

Installation Notes

- For best results we recommend using a HAEGER® machine to install PEM® rivet bushes. See our [website](#) for more information.
- View the installation animation on www.pemnet.com.
- For a flush installation, we recommend using the fastener designed for the next smallest sheet code.
- For the installation of rivet bushes in stainless steel sheets, we recommend using the fastener designed for the next smallest sheet code. For example, if installing an RABS-M3 fastener into 1.1 mm stainless steel, use RABS-M3-09 instead of RABS-M3-11.

All PEM® products meet our stringent quality standards. If you require additional industry or other specific [quality certifications](#), special procedures and/or part numbers are required. Please contact your local sales office or representative for further information.

Regulatory [compliance information](#) is available in Technical Support section of our website. Specifications subject to change without notice. See our website for the most current version of this bulletin.



North America: Danboro, Pennsylvania USA | E-mail: info@pemnet.com | Tel: +1-215-766-8853 | 800-237-4736 (USA)

Europe: Galway, Ireland | E-mail: europa@pemnet.com | Tel: +353-91-751714

Asia/Pacific: Singapore | E-mail: singapore@pemnet.com | Tel: +65-6-745-0660

Shanghai, China: E-mail: china@pemnet.com | Tel: +86-21-5868-3688

Visit our PEMNET™ Resource Center at www.pemnet.com • Technical support e-mail: techsupport@pemnet.com