



INNOVATION

BRIEF

A PEM® custom capability

Industry Problem: PennEngineering recognises there are challenges meeting sealing requirements using many fastening methods and also the need to reduce total installed cost

Innovation: PEMSET™ Fastener for “no hole” installation

The PEMSET™ fastener is installed by squeezing them into place with any standard press. No hole is required. The squeezing action embeds the fastener into the panel. The metal displaced flows smoothly and evenly around the annular groove – securely locking the fastener into the sheet with high torque-out and pushout resistances.

Features and Benefits

- Does not require a hole in the panel
- Does not put a hole into the panel
- Deforms the panel around the part
- Eliminates loose hardware
- Sealing capability
- Reduced total installed cost
- Can be provided in many different types and styles



Specifications

- Typically for installation into aluminium
- Fastener available in steel or stainless steel
- Variations may include studs, standoffs, pins, and others

Unlike fasteners that require a special hole to be prepared in the panel, the PEMSET™ fastener can be installed directly. This greatly reduces the cost of panel preparation.

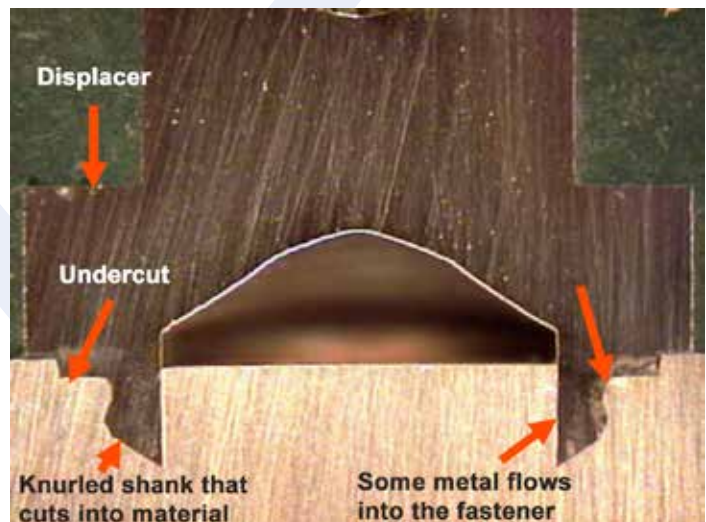
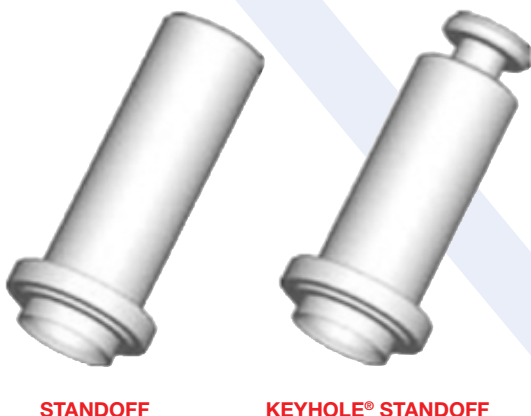

Innovation Brief / PEMSET™ Fastener for “no hole” installation

The fact that there is no hole on the opposite side of the panel makes this fastener very suitable for enclosures that must be sealed.

Challenges for enclosure assembly

- Cost reduction
- Drill and tap
- Poor sealing
- Poor external finish for cosmetic appearance and painting

The product or concept presented in this brief is not currently offered as a “standard” catalogued item. Products can be custom ordered at quoted prices, minimum order quantities and lead times to specifications within PEM® capabilities.

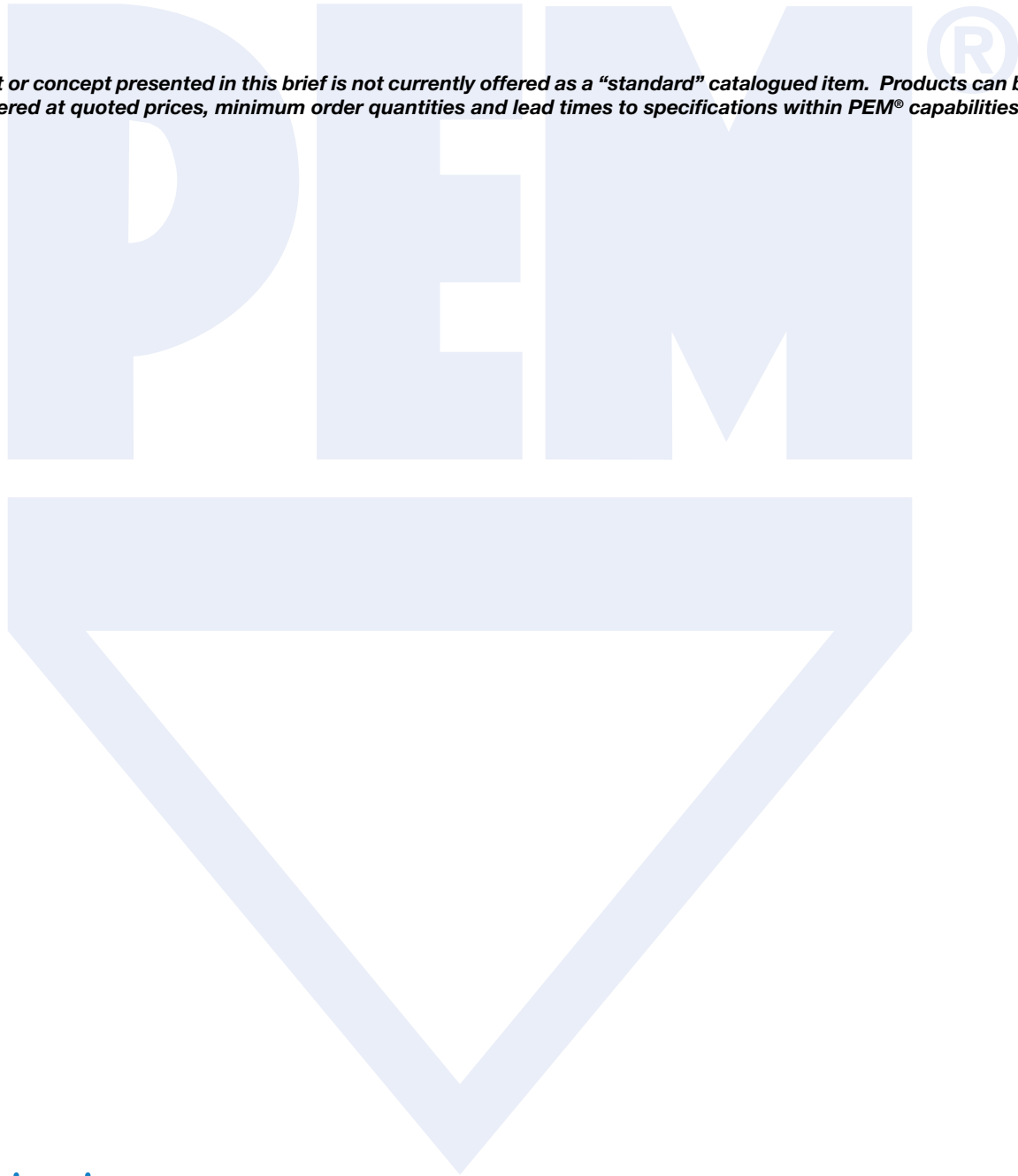

PennEngineering®



North America: Danboro, PA USA • E-mail: info@pemnet.com • Tel: +1-215-766-8853 • Fax: +1-215-766-0143 • 800-237-4736 (USA Only)

Europe: Galway, Ireland • E-mail: europe@pemnet.com • Tel: +353-91-751714 • Fax: +353-91-753541

Asia/Pacific: Singapore • E-mail: singapore@pemnet.com • Tel: +65-6-745-0660 • Fax: +65-6-745-2400
Shanghai, China • E-mail: china@pemnet.com • Tel: +86-21-5868-3688 • Fax: +86-21-5868-3988

Visit our PEMNET™ Resource Center at www.pemnet.com

Technical support e-mail: techsupport@pemnet.com