

TECH SHEET

PEM® REF/ REPAIR AND REPLACEMENT OF SELF-CLINCHING FASTENERS



SUBJECT: REPAIR AND REPLACEMENT OF SELF-CLINCHING FASTENERS

Properly installed self-clinching fasteners are designed to provide permanent load bearing threads in thin metal sheets. When installed the fasteners become an integral part of the host panel and will remain attached for the entire functional life of the end product.

However, should a mishap occur to your application after installation of our fasteners requiring replacement or repair of our product, we are happy to offer advice, recommendations, support or technical assistance. We can offer guidance of methods, processes and techniques through our customer service team, application engineers, our quality engineers as well as other technical support personnel globally.

Generally there are three main scenarios where repair or replacement may be necessary:

1. The fastener has been loosened in the panel.
2. The fastener has been damaged in some way:
 - A. The threads do not gauge
 - B. The fastener is damaged by an in-compatible finishing process
 - C. Manufacturing defect
3. The incorrect fastener was installed.

General Background Information -

Before discussing each of these scenarios individually a few general statements can be made which are applicable to all. It is always better to leave a self-clinching fastener in place than to remove it and install another fastener. If a fastener is loose in the panel it should not be removed and replaced unless the looseness is truly a problem and it cannot be corrected. If a fastener is damaged it should not be removed and replaced unless there is no possible way to repair it in place.

Repair and replacement of self-clinching fasteners is usually a relatively slow manual process and can be costly. Therefore a cost analysis should always be conducted to determine if repair or replacement makes economic sense. The decision should always consider that properly repaired or replaced parts will have adequate performance, but will almost always have lower performance than new parts that were installed correctly.

Experience has shown self-clinching fasteners are used in a wide variety of panels ranging from simple stampings with four or fewer of the same fasteners installed to large chassis with 20 or more fasteners of varying types and sizes. Typically repair or replacement is only warranted for higher cost panels. It may also be warranted if the problem is not discovered until a simple panel has been assembled into a larger and more expensive unit.

TECH SHEET

PEM® REF/ REPAIR AND REPLACEMENT OF SELF-CLINCHING FASTENERS



Testing implies that there is a defined requirement for clinch performance. Catalog values of pushout and torque-out certainly can be used as the requirement, but may not be achievable in these situations. It may be beneficial to define “adequate performance” based on known parameters of the application. For example, if mating hardware will be installed manually, 100 pounds of push-out or less may be adequate because most workers cannot apply more force than that. If the tightening torque is known to be 10 N•m, 7 N•m of torque-out may be adequate because the fastener will never see more than 70% of the tightening torque (the remainder goes to friction at the face of the turning member.)

Fastener Loose in Panel

Loose fasteners are usually detected either because they can be wiggled by hand or because they make a different sound when struck. **It is important to note that a fastener detected as loose may still have very good clinch performance.** In this case, the first response should be to test clinch feature strength by push-out and torque-out. If clinch performance meets requirements, no corrective action may be required for nuts and studs. These fastener types will be pulled in tighter to the sheet when torque is applied to the mating hardware.

If the performance does not meet requirements or if the fastener in question is a standoff (which will not be pulled tighter) then the loose condition should be corrected following the steps below.

There are four common causes of loose fasteners:

- 1. Fastener was not properly (fully) installed.** Most PEM® brand self-clinching fasteners include a positive stop feature that allows visual confirmation of a successful installation. Consult the proper PEM product bulletin for correct installation procedure.
- 2. Fastener was loosened by mechanical damage from panel handling after installation.** Long studs and long standoffs are most vulnerable to this type of damage because an impact force applied at the end of a long part applies a large moment to the clinch feature. This type of damage is best detected by examining the parts under lower power magnification (4 or 5X). Look for marks that may indicate contact force. The prognosis for this type of damage depends on the type and severity of the damage.
- 3. The panel was exposed to extreme temperatures after the fasteners were installed.** Temperature exposure causes differential thermal expansion which may slightly loosen the fasteners. The process temperatures after installation should be reviewed to determine if they could have caused loosening. Typically exposures to temperature variations over 300°F (150°C) are required to cause any detectable loosening. Fasteners loosened this way usually maintain their clinch performance.
- 4. The panel is harder than what is recommended in the literature for that particular fastener.** Self-clinching fasteners need to be a certain amount harder than the panel in order to clinch properly. All catalog bulletins list maximum hardness, so this can easily be confirmed by measuring actual panel hardness and verifying the fastener type. If the wrong fastener was used the over-installation techniques listed below may work, but it might also be an indication that replacement should be considered. This issue comes up on occasion when the user attempts to (incorrectly) install 300 Series stainless fasteners into a 300 Series stainless panel. To find the correct fasteners for this application PEM Bulletin SS should be consulted.

TECH SHEET

PEM® REF/ REPAIR AND REPLACEMENT OF SELF-CLINCHING FASTENERS



Fastener not fully installed - Solution

If the fasteners are not fully installed the installation should be repeated until visual confirmation is achieved. The fasteners can then be re-tested. If the assembly is not press accessible, and the thread size is large enough, it may be possible to use a rotary adaptor to pull them into the sheet. See **Table I** for rotary adaptor limitations.

If the fastener is loose but appears fully installed then an attempt should be made to displace more panel material into the undercut of the clinch profile. This can be tried either by over-installing or by using a raised ring anvil.

Over-installing can only be done when the panel thickness exceeds the specified minimum by at least the over-install distance and when the fastener will not be damaged by the required force. Depth of over-install will need to be determined experimentally but typically will be in the area of .002" to .005" (.05 to .125 mm). A sectioned view of an over-installed S type nut is shown in **Figure 1a**. Note that extra material is displaced by embedding a portion of the head into the panel. This does not require special tooling, but requires high force. This method risks head compression which can cause tight threads for S type nuts.

A sectioned view of an over-installed non flush-head stud is shown in **Figure 1b**. Again, no special tooling is required and the additional displacement is achieved by embedding a portion of the head into the panel.

Table I - Force capacity of rotary adapters for repair/replace

Thread Size ⁽¹⁾	Rotary Adapter Part Number	Max. Force Capacity ⁽²⁾
032	TH-032	2,880 lbs
0420	TH-0420	4,580 lbs
0518	TH-0518	7,550 lbs
0616	TH-0616	11,160 lbs
0813	TH-0813	20,400 lbs
M5	TH-M5	13.8 kN
M6	TH-M6	19.6 kN
M8	TH-M8	35.7 kN
M10	TH-M10	56.5 kN

(1) Rotary adapters are not practical in thread sizes smaller than #10/M5. Thread sizes larger than 1/2"/M10 are possible, but are not currently defined.

(2) Rotary adapters can only be used in applications where the required installation force is less than values in this column.

Figure 1a

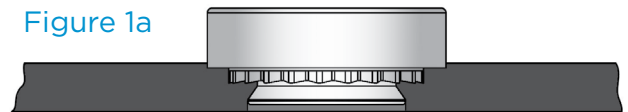

Over-installed type S nut, if anvil with nest is used, nest depth must be less than head height (catalog T dimension) minus depth of over-installation.

TECH SHEET

PEM® REF/ REPAIR AND REPLACEMENT OF SELF-CLINCHING FASTENERS



A sectioned view of an over-installed flush-head stud is shown in **Figure 1c** and a standoff is shown in **Figure 1d**. Note that for flush head studs and standoffs special contact tooling is required and rules for sizing that tooling are given in the captions. For these styles extra panel material is displaced by the contact tooling.

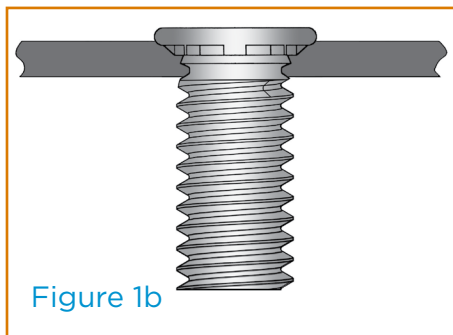

Figure 1b

Over-installed non-flush head stud, if punch with nest is used, nest depth must be less than head height (catalog T dimension) minus depth of overinstallation.

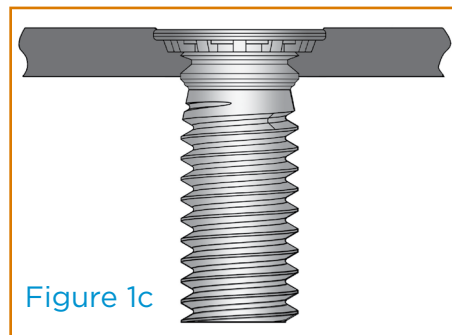

Figure 1c

Over-installed flush head stud, requires special punch with diameter equal to max head diameter.

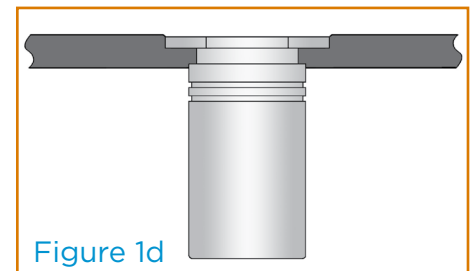

Figure 1d

Over-installed standoff, requires special punch with diameter equal to the nominal across points dimension of the hex or knurled head.

The **raised ring anvil technique** is illustrated in **Figure 2a** for type S clinch nuts and similar designs. **Figures 2b** and **2c** illustrate the raised ring anvil for studs and standoffs. The effectiveness of a raised ring anvil is limited in thicker panels. As a rule of thumb for S type nuts and standoffs raised ring anvils have little or no effect if the actual panel thickness is over 1.5 times the minimum panel thickness specified for the fastener. For studs, raised ring anvils can be effective for increasing pushout in thick panel because they can displace material into the threads.

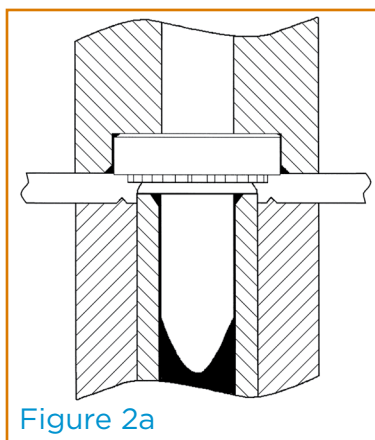

Figure 2a

Raised ring anvil for type S nut, dimensions of raised ring vary by application and may need to be determined experimentally.

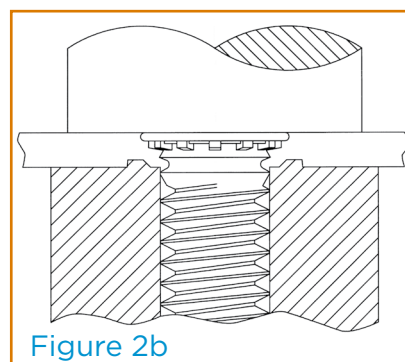

Figure 2b

Raised ring anvil for stud, dimensions of raised ring vary by application and may need to be determined experimentally. Chamfered anvil shown, but thicker sheet applications should not use a chamfer.

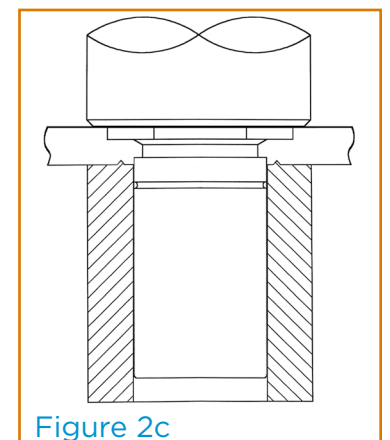

Figure 2c

Raised ring anvil for standoff, dimensions of raised ring vary by application and may need to be determined experimentally. Anvil without chamfer shown, but thinner sheet applications may require a chamfer.

TECH SHEET

PEM® REF/ REPAIR AND REPLACEMENT OF SELF-CLINCHING FASTENERS



If these techniques do not adequately improve clinch performance, then replacement should be considered. Guidelines for replacement are the same for loose fasteners and for damaged fasteners and are given below.

Damaged Fasteners

First, we must say again that it is always better to leave a self-clinching fastener in place than to remove it and install another fastener. Of course the reasons for the problem should be identified and corrected before proceeding with any further installations

Three categories of fastener damage are covered here.

Installed Fastener Threads Not Gaugeable -

Some common causes of threads not gaging and how to detect them are as follows:

1. Tight threads in nuts caused by head compression from excessive installation force. This can be identified by one of the following conditions:
 - A. A Go threaded plug gage will enter from either end but will tighten up before going all the way through
 - B. The head height of an installed part is less than head height of the same part that is uninstalled.
 - C. The head diameter of the installed part is greater than the head diameter of the same part uninstalled.
2. Damaged threads in studs can be caused by improper clearance within the installation anvil hole. This type of damage is best detected by examining the threads (under low power magnification) for wipe marks in the axial direction.
3. Oversized external threads or undersized internal threads cause by re-plating after fastener installation. If this cause is suspected, plating thickness on the fasteners should be measured by an appropriate method. Threads on standard fasteners are sized to accept a maximum of .0004 inch (10 microns) of plating. If the plating measures thicker it is likely the cause.

If the fastener material is soft enough and the panel is hard enough to give high torque-out resistance, it may be possible to repair a thread in place. In practice it is easier to access a nut with a tap than it is to access a stud with a threading die. Since it is more common, we will address the former in detail here. However, external thread repair is also possible using these general rules and a threading die.

To repair threads two torque relationships must exist:

1. The **torque required to tap** the nut must be less than the **breaking strength of the tap**.
2. The **torque required to tap** must be less than the **torque-out strength**.

The **three torque values above** can all be determined experimentally. If the original experiment results in tap breakage or nut spinning the following methods can be used to adjust these three torque values and potentially achieve success.

TECH SHEET

PEM® REF/ REPAIR AND REPLACEMENT OF SELF-CLINCHING FASTENERS



1. Tapping torque can be reduced in the following ways:
 - A. Use a tap with lowest PD that will produce a gaugeable thread, typically this will be an H2 or H1 limit or possibly an L1 limit. In some cases a gaugeable thread may not be required as long as the mating thread enters freely.
 - B. Use a tap with more flutes to reduce chip load.
 - C. Use a taper style tap with 5 to 8 threads chamfered to reduce chip load.
 - D. Apply a lubricant to the tap and/or threads.
 - E. Anneal the fastener to reduce its hardness – this is only practical for un-plated steel or stainless steel and the annealing cycle for the fastener must also be compatible with the panel.
2. Tap breaking strength can be increased by having the tap manufacturer use a stronger tool steel and/or use a larger minor diameter.
3. Fastener torque-out may be able to be increased by intentionally over installing as described above, but this adds repair cost and is rarely justifiable.

Fastener material has a strong influence on tapping torque. Unfortunately most steel clinch fasteners are heat treated and thread repair is difficult or impossible. Chances are much better with aluminum or 300 series stainless steel fasteners.

Re-tapping plated steel parts will remove the plating from the threads making them susceptible to corrosion. This may be okay if the mating threads have a sacrificial plating such as zinc because that plating will provide some protection to the bare threads of the repaired fastener.

When thread repair is not possible the only options are to scrap or replace following the replacement guidelines on page 7.

Fastener Damaged by an Incompatible Finishing Process

PennEngineering provides detailed guidance on finishing sheet metal assemblies after self-clinching fasteners have been installed in a Tech Sheet available at the following link. www.pemnet.com/design_info/techsheets/Surface_Finish.pdf

However, if these recommendations are not followed, fasteners can be damaged. Repair options depend on the severity of the damage. If steel fasteners are installed in an aluminum panel and the assembly is anodized, fastener damage will be severe and the only potential repair option is to remove and replace the fastener. At the other end of the damage spectrum if installed stainless fasteners are discolored by a passivation process that was not compatible with the fastener alloy, repair may be possible by using a passivation process compatible with both the fastener alloy and the panel alloy.

TECH SHEET

PEM® REF/ REPAIR AND REPLACEMENT OF SELF-CLINCHING FASTENERS



Wrong Fastener Installed -

This category includes items such as the following:

1. A nut with unified threads being installed instead of the same body size nut with metric threads
2. The wrong length of stud or standoff installed
3. Non-locking type FEX installed when locking type FE was specified

For these types of errors there is no repair possible and the only options are to scrap or replace following the replacement guidelines on page 7.

Clinch Fastener Replacement Guidelines

When replacement of a clinch fastener is the only remaining option:

The first step is to remove the existing fastener from the panel. Removal is best accomplished with a set-up similar to that used to test clinch feature push-out strength. This is shown in Figures 2 and 3 on page 3 of the TechSheet on testing clinch performance at the link below.
http://www.pemnet.com/design_info/techsheets/Testing_Clinch_Performance.pdf

Support bushing configuration and means of applying load to the thread may need to be configured differently to accommodate the shape of the panel. Keep in mind that the fastener is being removed so that a replacement fastener can be installed and therefore the significantly higher installation force will also need to be applied to the fastener and the panel adequately supported. In some cases the panel shape may not allow the access needed for removal and replacement. In those situations repair may not be possible. If panel shape allows adequate access, start by removing several fasteners and observe whether a ring of panel material is present in the undercut.

If no ring is present, there is a reasonable chance of success installing the same part number in the hole. It may however be technically more desirable to install a different sized part.

If a ring is present, panel material has been removed and installing the same part is not likely to be successful. When this is the case, there are two options. First, it may be possible to use a longer shank or larger body size clinch fastener as discussed in the section below. Second, if the application is for a nut and does not require the fastener to be sub flush on the shank side, an Atlas brand blind threaded insert should be considered. Similarly if the application is for a stud and can accommodate a thin head on the thread side and a taller head on the head side, an Atlas brand blind stud should be considered. Atlas hole sizes and part styles are included in Table III. Keep in mind that unlike clinch fasteners which typically require only a minimum sheet thickness, Atlas brand blind fasteners typically specify a grip range. Parts must be chosen so that the panel thickness is within the listed grip range. Grip ranges are not included in Table III.

TECH SHEET

PEM® REF/ REPAIR AND REPLACEMENT OF SELF-CLINCHING FASTENERS



The following section gives some guidelines on using different part numbers for replacement.

The best choice to replace a type S clinch nut is to use a longer shank length if the minimum sheet thickness is within specification. The longer shank will provide a larger displacer and therefore move more panel material into the undercut than the previous fastener.

The next choice in this situation is to use a larger body part with the same thread size. In some cases a larger body part is available in the same part series. In other cases a different fastener type may have to be used.

Table II - Possible replacement types for selected self-clinching fastener types

Type	Possible Replacement Part Number
AS, AC	No replacement type
B, BS	See Type S for non-blind options
CLA	See Table III
CLS	See Type S
DSOS	SO or SOS head is larger across hex points
F	See Table III
FE, FEO	PLC or LKS is most cases, see Table III
FEX, FEOX	See Table III
FH, FHS	Type CHC/CFHC uses larger hole, but has lower pull-thru strength
FHL, FHLS	FH or FHS if centerline-to-edge distance is adequate
HFH	HFE has larger rib diameter
HFE	HF109/HFG8 has larger rib diameter
HF109/HFG8	No replacement type
LK, LKS, LKA	PL, PLC in most cases, see Table III
PL, PLC	No replacement type
S	CLA for aluminum panel and small thread sizes, also see Table III
SO, SOS, SOA	Type CSS/CSOS, CSA/CSOA uses larger hole, but has lower pull-thru strength
SP	No replacement type with equivalent hardness and corrosion resistance
TFH, TFHS	FH or FHS if sheet thickness is adequate
TPS	No replacement type
TSO, TSOS	SO or SOS has thicker head if sheet thickness is adequate

TECH SHEET

PEM® REF/ REPAIR AND REPLACEMENT OF SELF-CLINCHING FASTENERS



Table III - Mounting hole size comparison for selected nuts

Thread Size	Nut Type	Nominal Mounting Hole Diameter (in.)
256	SMPS	.136
	U	.140
	KF2	.147
	CLA	.166
	S	.166
	F	.172
440	LK	.172
	KF2	.166
	S	.166
	SMPS	.166
	F	.172
	FE	.172
	LK	.187
	N10	.187
632	CLA	.1875
	PL	.234
	SMPS	.187
	S	.1875
	MaxTite®	.189
	CLA	.213
	F	.213
	FE	.213
	KF2	.213
	N10	.213
	LK	.219
	AEOS	.250
	PL	.265
	AEKS/AELS	.266
832	S	.213
	MaxTite®	.221
	CLA	.234
	KF2	.250
	N10	.250
	AEOS	.250
	LK	.266
	AEKS/AELS	.266
	F	.290
	FE	.290
	PL	.297
	032	MaxTite®
S		.250
KF2		.272
N10		.277
AEKS/AELS		.281
FE		.290
CLA		.296
AEOS		.297
F		.312
LK		.312
PL		.312

Thread Size	Nut Type	Nominal Mounting Hole Diameter (mm)
M2	U	3.61
	KF2	3.73
	CLA	4.22
	S	4.22
M2.5	SMPS	3.8
	KF2	4.22
	S	4.22
	F	4.37
	LK	4.37
M3	KF2	4.22
	S	4.22
	SMPS	4.24
	F	4.37
	FE	4.39
	LK	4.75
	N10	4.75
	CLA	4.75
	PL	6
	M3.5	SMPS
S		4.75
CLA		5.41
M4	S	5.41
	MaxTite®	5.6
	CLA	5.94
	N10	6.35
	AEKS/AELS	6.4
	KF2	6.4
	AEOS	6.75
	LK	6.76
	F	7.37
	FE	7.39
	PL	7.5
M5	S	6.35
	KF2	6.9
	N10	7.04
	AEOS	7.2
	MaxTite®	7.2
	FE	7.39
	CLA	7.52
	AEKS/AELS	7.6
	F	7.92
	LK	7.92
	PL	8

NOTE: Nut types shown in blue are ATLAS® brand blind threaded inserts, not self-clinching and not flush on the shank side. Fewer choices exist for larger thread sizes. Contact Technical Support at techsupport@pemnet.com for details

TECH SHEET

PEM® REF/ REPAIR AND REPLACEMENT OF SELF-CLINCHING FASTENERS



Table II lists clinch fastener prefixes alphabetically and makes recommendations for replacement types. **Table III** compares mounting holes for selected nut part types and their recommended replacement type. Table III can be used directly by first finding the correct block for the thread size and then finding the existing type in the second column. Any type lower down in the block with a larger mounting hole is a potential replacement type.

Replacement Procedure:

Before a replacement part is installed the existing part must be removed per above.

If the same part number or a longer shank version of the same part type is being installed, the hole should be resized by pushing a tapered punch into it. Ideally this should be done from the shank side (the side opposite the side which the fastener will be installed) so any axial material movement is toward the displaced area. If there is no longer adequate access length from the shank side, it can be done from the head side. If a part with a larger mounting hole is to be installed the mounting hole should be drilled to the required size.

After, the replacement part number and the hole preparation method has been selected, the next step is to prepare several holes, install the chosen part number and test the clinch performance. If the clinch performance meets requirements a replacement procedure has been identified. In some cases it may be advisable to test a higher number of samples to verify the robustness of the repair procedure before applying it to a large number of panels.

If clinch performance does not meet requirements the chances for success may be less likely, but there may still be some things to try. If the replacement part used the same hole, it may be time to try a different part series which requires creating a new larger hole. If that option has already been used, over-installing the replacement part as described above can be tried and clinch performance tested again. In some cases repair may not make economic sense and the work will need to be scrapped and re-made. When this is the case, it is important that the cause of the problem has been found during the repair/replace investigation so that the replacement part manufacturing process can be modified to eliminate the cause of the problem.

This Tech Sheet addresses some of the more common application situations PennEngineering has experienced in dealing with self-clinching fastener customers over the years. It is understood that not all possible situations can be covered in this format. If you require further technical assistance please e-mail techsupport@pemnet.com for assistance.

In all cases, performance will likely be reduced and won't achieve catalog results. Always test performance to evaluate if performance achieved meets your part application requirements.