



RIV912

**PULL-TO-STROKE SPIN-PULL TOOL
FOR RIVET NUTS FROM #4-40 TO 1/2" AND M3 TO M12
AND RIVET STUDS #8-32 TO 5/16" AND M4 TO M8**

OPERATING INSTRUCTIONS



PennEngineering®



North America: Danboro, PA USA • E-mail: atlas@pemnet.com • Tel: +1-215-766-5987 • Fax: +1-215-766-5988 • 877-682-2505 (USA Only)
Europe: Galway, Ireland • E-mail: europe@pemnet.com • Tel: +353-91-751714 • Fax: +353-91-753541
Asia/Pacific: Singapore • E-mail: singapore@pemnet.com • Tel: +65-6-745-0660 • Fax: +65-6-745-2400
Shanghai, China • E-mail: china@pemnet.com • Tel: +86-21-5868-3688 • Fax: +86-21-5868-3988

Visit our PEMNET™ Resource Center at www.pemnet.com



**NOTE: THE RIV912 TOOL COMES WITHOUT NOSE ASSEMBLY KITS.
NOSE ASSEMBLY KITS HAVE TO BE ORDERED SEPARATELY ACCORDING TO THE USER NEEDS.**

1. Kit assembly with toothed ring nut (wrench is no longer necessary).
2. Tie rods are now replaced by commercial screws.
3. One position trigger mechanism.
4. Light weight.
5. Convenient.
6. The adjustment ring can be blocked using the nut.
7. Easily adjusted after tooling changeover.

GENERAL INFORMATION

MANUFACTURER

Rivit S.r.l. was born in 1973, it produces and distributes in Fasteners and Tools for Fixings (tools for rivets and rivet nuts). The Company boasts much technical experience and offers a wide range of products related to fastening systems.

ASSISTANCE

In case you need any assistance concerning the use and the maintenance of the tool, or in case you need to order any spare parts, you shall contact your local authorised dealer (or Rivit S.r.l. directly) specifying the identification/serial numbers of the tool, written on its outer casing.

CERTIFICATION AND EC MARKING

The tool is manufactured in compliance with the European Directives, which are in force when the tool itself is put on the market. As the tool is not included in ENCLOSURE IV of DIRECTIVE 2006/42/EC, Rivit S.r.l. issues a self-certification to apply the EC marking.

WARRANTY

The warranty has a validity of 12 months, as of the date indicated on the invoice.

The warranty only covers replaced parts; labor is not included.

The following are not covered by warranty: standard accessories and tool damages caused by:

- transport and/or handling, user's mistakes,
- failed servicing/maintenance, as indicated in section 7 of this manual,
- faults and/or breakages that are not attributable to tool anomalies,
- normal consumption of consumables.

The warranty is invalidated both in case of unauthorized tampering/replacements of tool components and in case of use of accessories, tools or consumables different to those recommended by the manufacturer, which could even cause injuries to the tool's user.

Rivit S.r.l. assumes responsibilities only if the tool is originally defective, but declines all forms of responsibility if the user fails to follow the instructions given.

OPERATING SYSTEM

The hydro-pneumatic RIV912 tool, with oil pressure regulation, is designed to place female threaded inserts (from #4-40 to 1/2" and M3 to M12) and male threaded inserts (from #8-32 to 5/16" and M3 to M8). The hydro-pneumatic system and the mechanical components used inside the RIV912, when compared with other riveting tools, are more reliable. There is less wear and tear of the components, consequently the tool will last much longer and work better. The technical solutions adopted make the RIV912 more compact and lighter.

MANUAL STRUCTURE

This instruction manual must be read with particular attention by the Customer, as the correct pre-arrangement, installation and use of the tool, are the correct basis for a good relationship between Manufacturer and Customer.

PURPOSE AND CONTENTS

The manual herein has the purpose of providing the Customer with all the information needed not only to use the tool correctly, but also to manage it self-sufficiently and safely. It includes information concerning technical aspects, operation, maintenance, spare parts and safety.

Users and Qualified Technicians must read the instructions given herein thoroughly before starting to use the tool. If you have any doubts on the meaning of the instructions given, please do not hesitate to contact Rivit S.r.l. for further explanations.

RECEIVERS

The manual herein has been written for both the operators and the technicians enabled to service the tool. Operators must not carry out jobs reserved to service and/or qualified technicians. Rivit S.r.l. is not liable for any damage deriving from the failed observance of this rule.

PLACING OF THE MANUAL

This instruction manual must be kept near the tool, inside a dedicated container and, above all, away from liquids or anything else that may compromise its legibility.

OPERATING SYSTEM

The hydro-pneumatic RIV912 tool, with oil pressure regulation, is designed to place the following fasteners:

- Female threaded rivet nuts (from #4-40 to 1/2" and M3 to M12)
- Male threaded rivet studs (from #8-32 to 5/16" and M4 to M8)

The hydro-pneumatic system and the mechanical components used in the inside structure of the RIV912, when compared with other riveting tools, result to be much more reliable. A tool feature is a reduction of the problems caused by the wear and tear of the components, and consequently the tool will last much longer and work better. The technical solutions adopted make the RIV912 more compact and lighter: the result is a very handy tool.

VIBRATION

When used correctly, the tool does not produce any dangerous vibration.

NOISE LEVEL

The tool is designed and manufactured in such a way that the noise level is very low. The weighed equivalent continuous acoustic pressure level A in the operator position is indeed below 80 dB (A).

This information can allow the tool user to better evaluate the possible risks of danger.

TECHNICAL DATA

The following table provides the technical data and features of the tool, to which you must refer when contacting the ATLAS® Technical Assistance Department at PennEngineering.

TECHNICAL DATA AND FEATURES

AIR WORKING PRESSURE	90 PSI / 6 BAR
MAX AIR PRESSURE	70 to 100 PSI / 5 to 7 BAR
AIR CONSUMPTION PER CYCLE AT 6 BAR	457.5 cu. in. 7.5 liter
MAX STROKE	.256" / 6.5 mm
MAX. AXIAL PULLING LOAD	4721 lbs @ 90 PSI 21 kN @ 6 BAR
MOTOR SPEED (SPIN ON)	1600 rpm
MOTOR SPEED (SPIN OFF)	2000 rpm
WEIGHT	5 lbs. / 2.3 kg
VIBRATIONS	< 2.5 m/s ²
NOISE LEVEL	78.5 dB (A)

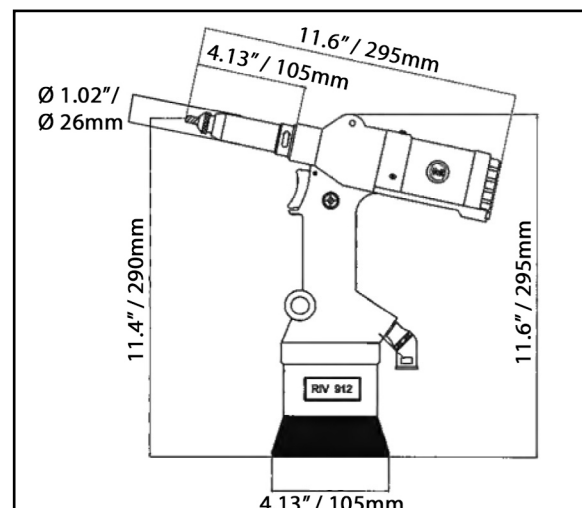

NOSE ASSEMBLIES AND STANDARD ACCESSORIES

The nose assemblies stated hereafter refers to standard tools.

Any special tool could consequently require special parts, different than those listed.

REF.	PART NUMBER	QTY	DESCRIPTION
1	3440900	1	RIV912-HYDRO-PNEUMATIC TOOL FOR INSERTS (IN PVC CASE)
2	2533800	1	EMERGENCY AND STROKE REGULATION PIN
3	0207300	1	UNIVERSAL KEY
4	3064400	1	HYDRAULIC OIL TYPE ISO VG 32 100CC
5	4091400	1	RUBBER PROTECTION
—	—	1	INSTRUCTION MANUAL

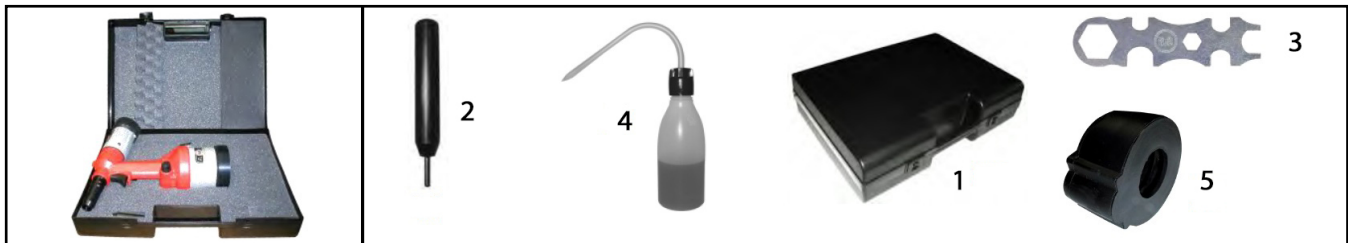

OPTIONAL ACCESSORIES

Depending on the fastener style, different accessories are available.

KIT FOR SPECIAL HEAD. EXTENSION ON REQUEST: NOT INCLUDED IN THE STANDARD ACCESSORIES

The nose assemblies stated hereafter refers to standard tools.

Any special tool could consequently require special parts, different than those listed.



REF.	PART NUMBER	QTY	DESCRIPTION
1	3531800	1	KIT 912 - SPECIAL EXTENDED HEAD

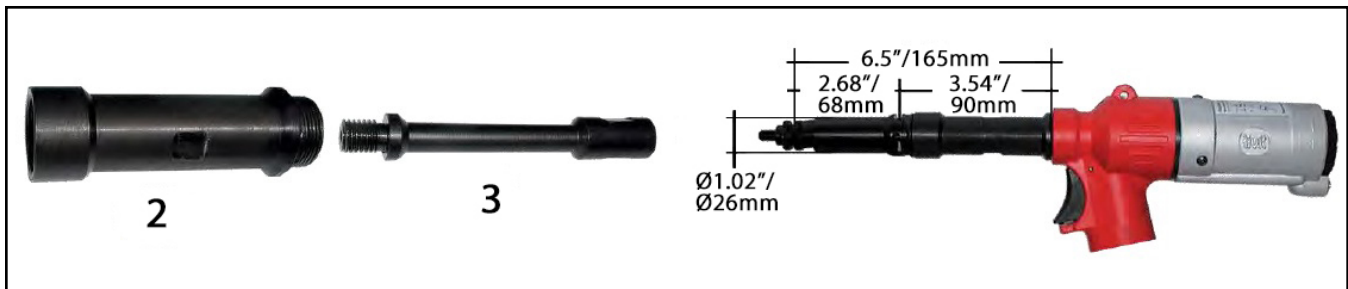

REF.	PART NUMBER	QTY	DESCRIPTION
2	3446600	1	90 MM EXTENDED SLEEVE
3	3446900	1	90 MM INTERNAL EXTENDED SLEEVE

You can reach a total head extension of 6.5"/165 mm with the above two items.

OPTIONAL TOOLING

For Blind Threaded Insert Installation.

NOSE ASSEMBLY PART NUMBERS

Thread Size	Part No. For Complete Insert Nose Assembly	Part No. For Replacement SHCS / Mandrel ⁽¹⁾
#4-40	4326700	MC-91251A078 (50/box)
#6-32	3755100	IN-14328 (100/box)
#8-32	3755500	IN-03190 (100/box)
#10-24	—	IN-08823 (100/box)
#10-32	3755900	IN-07085 (100/box)
1/4-20	3756100	IN-05336 (100/box)
1/4-28	—	IN-08057 (100/box)
5/16-18	3756300	IN-04153 (100/box)
5/16-24	—	IN-10834 (100/box)
3/8-16	3756700	IN-15776 (100/box)
3/8-24	—	IN-16488 (50/box)
1/2-13	4361600	—
M3	3441100	IN-06219 (200/box)
M4	3441200	IN-03023 (200/box)
M5	3441300	IN-03038 (200/box)
M6	3441400	IN-13128 (200/box)
M8	3441500	IN-21070 (100/box)
M10	3441600	IN-03088 (100/box)
M12	3441700	—



Nose assembly screws into here

Insert Nose Assembly

(1) Replacement mandrels sold in box quantities shown above.

HEAD RING NUT

Can be ordered separately. Part number 0327700.



KIT FOR BLIND THREADED INSERT #4-40



REF.	PART NUMBER	QTY	DESCRIPTION
1	4326700	1	KIT FOR BLIND THREADED INSERT #4-40 SOCKET HEAD CAP SCREW

KIT COMPOSITION



REF.	PART NUMBER	QTY	DESCRIPTION
2	4326300	1	HEAD WITH RING NUT FOR #4-40 SCREW
3	4326400	1	ADAPTER FOR #4-40 SCREW (HOLE Ø 3.0)
4	MC-91251A078 (50/box)	1	SOCKET CAP SCREW #4-40 X 1.5"
5	4326500	1	HEXAGONAL JOINT WITH SPRING FOR #4-40 SCREW

KIT FOR BLIND THREADED INSERT #6-32

REF.	PART NUMBER	QTY	DESCRIPTION
1	3755100	1	KIT FOR BLIND THREADED INSERT #6-32 SOCKET HEAD CAP SCREW

KIT COMPOSITION

REF.	PART NUMBER	QTY	DESCRIPTION
2	3755200	1	HEAD WITH RING NUT FOR #6-32 SCREW
3	3753300	1	ADAPTER FOR #6-32 SCREW (HOLE Ø 3.6)
4	IN-14328 (100/box)	1	SOCKET CAP SCREW #6-32 X 1.5"
5	3753400	1	HEXAGONAL JOINT WITH SPRING FOR #6-32 SCREW

KIT FOR BLIND THREADED INSERT #8-32



REF.	PART NUMBER	QTY	DESCRIPTION
1	3755500	1	KIT FOR BLIND THREADED INSERT #8-32 SOCKET HEAD CAP SCREW

KIT COMPOSITION



REF.	PART NUMBER	QTY	DESCRIPTION
2	3755600	1	HEAD WITH RING NUT FOR #8-32 SCREW
3	3753800	1	ADAPTER FOR #8-32 SCREW (HOLE Ø 4.2)
4	IN-03190 (100/box)	1	SOCKET CAP SCREW #8-32 X 1.5"
5	3753900	1	HEXAGONAL JOINT WITH SPRING FOR #8-32 SCREW

KIT FOR BLIND THREADED INSERT #10-32

REF.	PART NUMBER	QTY	DESCRIPTION
1	37555900	1	KIT FOR BLIND THREADED INSERT #10-32 SOCKET HEAD CAP SCREW

KIT COMPOSITION

REF.	PART NUMBER	QTY	DESCRIPTION
2	3755600	1	HEAD WITH RING NUT FOR #10-32 SCREW
3	3471700	1	ADAPTER FOR #10-32 SCREW (HOLE Ø 5.0)
4	IN-07085 (100/box)	1	SOCKET CAP SCREW #10-32 X 2.25"
4	IN-08823 (100/box)	1	SOCKET CAP SCREW #10-24 X 2.25"
5	3472000	1	HEXAGONAL JOINT FOR #10-32 SCREW

KIT FOR BLIND THREADED INSERT 1/4-20



REF.	PART NUMBER	QTY	DESCRIPTION
1	3756100	1	KIT FOR BLIND THREADED INSERT 1/4-20 SOCKET HEAD CAP SCREW

KIT COMPOSITION



REF.	PART NUMBER	QTY	DESCRIPTION
2	3756200	1	HEAD WITH RING NUT FOR 1/4-20 SCREW
3	3754600	1	ADAPTER FOR 1/4-20 SCREW (HOLE Ø 6.5)
4	IN-05336 (100/box)	1	SOCKET CAP SCREW 1/4-20 X 2.25"
4	IN-08057 (100/box)	1	SOCKET CAP SCREW 1/4-28 X 2.25"
5	3754700	1	HEXAGONAL JOINT FOR 1/4-20 SCREW

KIT FOR BLIND THREADED INSERT 5/16-18

1



REF.	PART NUMBER	QTY	DESCRIPTION
1	3756300	1	KIT FOR BLIND THREADED INSERT 5/16-18 SOCKET HEAD CAP SCREW

KIT COMPOSITION

REF.	PART NUMBER	QTY	DESCRIPTION
2	3756400	1	HEAD WITH RING NUT FOR 5/16-18 SCREW
3	3755300	1	ADAPTER FOR 5/16-18 SCREW (HOLE Ø 8.1)
4	IN-04153 (100/box)	1	SOCKET CAP SCREW 5/16-18 X 2.25"
4	IN-10834 (100/box)	1	SOCKET CAP SCREW 5/16-24 X 2.25"
5	3755000	1	HEXAGONAL JOINT FOR 5/16-18 SCREW

KIT FOR BLIND THREADED INSERT 3/8-16

1



REF.	PART NUMBER	QTY	DESCRIPTION
1	3756700	1	KIT FOR BLIND THREADED INSERT 3/8-16 SOCKET HEAD CAP SCREW

KIT COMPOSITION



REF.	PART NUMBER	QTY	DESCRIPTION
2	3756800	1	HEAD WITH RING NUT FOR 3/8-16 SCREW
3	IN-15776 (100/box)	1	SOCKET CAP SCREW 3/8-16 X 2.5"
3	IN-16488 (50/box)	1	SOCKET CAP SCREW 3/8-24 X 2.5"
4	3755700	1	HEXAGONAL JOINT FOR 3/8-16 SCREW

KIT FOR BLIND THREADED INSERT 1/2-13

REF.	PART NUMBER	QTY	DESCRIPTION
1	4361600	1	KIT FOR BLIND THREADED INSERT 1/2-13

KIT COMPOSITION

REF.	PART NUMBER	QTY	DESCRIPTION
2	4378400	1	M8X6 SOCKET CAP SCREW NUT
3	4378500	1	M8 - 1/2-13 UNC DOUBLE THREAD BUSH
4	4378600	1	HEAD (HOLE Ø 8.1)
5	3472600	1	ADAPTER (HOLE Ø 8.1)
6	4187000	1	M8X70 SOCKET HEAD CAP SCREW 8.8, UNI 5931
7	3472900	1	HEXAGONAL JOINT FOR M8 SCREW

KIT FOR BLIND THREADED INSERT M3



REF.	PART NUMBER	QTY	DESCRIPTION
1	3441100	1	KIT FOR BLIND THREADED INSERT M3 SOCKET HEAD CAP SCREW

KIT COMPOSITION



REF.	PART NUMBER	QTY	DESCRIPTION
2	3457500	1	HEAD WITH RING NUT FOR M3 SCREW
3	3457400	1	ADAPTER FOR M3 SCREW
4	IN-06219 (200/box)	1	SOCKET CAP SCREW M3X40 12.9 UNI5931/DIN912
5	3466200	1	HEXAGONAL JOINT WITH SPRING FOR M3 SCREW

On request, we can provide a longer screw than the standard one.

REF.	PART NUMBER	QTY	DESCRIPTION
4a	2193500	1	SOCKET CAP SCREW M3X50 12.9 UNI5931/DIN912

KIT FOR BLIND THREADED INSERT M4

REF.	PART NUMBER	QTY	DESCRIPTION
1	3441200	1	KIT FOR BLIND THREADED INSERT M4 SOCKET HEAD CAP SCREW

KIT COMPOSITION

REF.	PART NUMBER	QTY	DESCRIPTION
2	3470200	1	HEAD WITH RING NUT FOR M4 SCREW
3	3466300	1	ADAPTER FOR M4 SCREW
4	IN-03023 (200/box)	1	SOCKET CAP SCREW M4X55 12.9 UNI5931/DIN912
5	3470600	1	HEXAGONAL JOINT WITH SPRING FOR M4 SCREW

On request, we can provide a longer screw than the standard one.

REF.	PART NUMBER	QTY	DESCRIPTION
4a	4186400	1	SOCKET CAP SCREW M4X65 12.9 UNI5931/DIN912

KIT FOR BLIND THREADED INSERT M5



REF.	PART NUMBER	QTY	DESCRIPTION
1	3441300	1	KIT FOR BLIND THREADED INSERT M5 SOCKET HEAD CAP SCREW

KIT COMPOSITION



REF.	PART NUMBER	QTY	DESCRIPTION
2	3471800	1	HEAD WITH RING NUT FOR M5 SCREW
3	3471700	1	ADAPTER FOR M5 SCREW
4	IN-03038 (200/box)	1	SOCKET CAP SCREW M5X55 12.9 UNI5931/DIN912
5	3472000	1	HEXAGONAL JOINT FOR M5 SCREW

On request, we can provide a longer screw than the standard one.

REF.	PART NUMBER	QTY	DESCRIPTION
4a	4285500	1	SOCKET CAP SCREW M5X65 12.9 UNI5931/DIN912

KIT FOR BLIND THREADED INSERT M6

REF.	PART NUMBER	QTY	DESCRIPTION
1	3441400	1	KIT FOR BLIND THREADED INSERT M6 SOCKET HEAD CAP SCREW

KIT COMPOSITION

REF.	PART NUMBER	QTY	DESCRIPTION
2	3472200	1	HEAD WITH RING NUT FOR M6 SCREW
3	3472100	1	ADAPTER FOR M6 SCREW
4	IN-13128 (200/box)	1	SOCKET CAP SCREW M6X55 12.9 UNI5931/DIN912
5	3472500	1	HEXAGONAL JOINT FOR M6 SCREW

On request, we can provide a longer screw than the standard one.

REF.	PART NUMBER	QTY	DESCRIPTION
4a	4285300	1	SOCKET CAP SCREW M6X65 12.9 UNI5931/DIN912

KIT FOR BLIND THREADED INSERT M8



REF.	PART NUMBER	QTY	DESCRIPTION
1	3441500	1	KIT FOR BLIND THREADED INSERT M8 SOCKET HEAD CAP SCREW

KIT COMPOSITION



REF.	PART NUMBER	QTY	DESCRIPTION
2	3472700	1	HEAD WITH RING NUT FOR M8 SCREW
3	3472600	1	ADAPTER FOR M8 SCREW
4	IN-21070 (100/box)	1	SOCKET CAP SCREW M8X60 12.9 UNI5931/DIN912
5	3472900	1	HEXAGONAL JOINT FOR M8 SCREW

On request, we can provide a longer screw than the standard one.

REF.	PART NUMBER	QTY	DESCRIPTION
4a	2192800	1	SOCKET CAP SCREW M8X65 12.9 UNI5931/DIN912

KIT FOR BLIND THREADED INSERT M10

1



REF.	PART NUMBER	QTY	DESCRIPTION
1	3441600	1	KIT FOR BLIND THREADED INSERT M10 SOCKET HEAD CAP SCREW

KIT COMPOSITION

REF.	PART NUMBER	QTY	DESCRIPTION
2	0329000	1	HEAD WITH RING NUT FOR M10 SCREW
3	IN-03088 (100/box)	1	SOCKET CAP SCREW M10X60 12.9 UNI5931/DIN912
4	3441800	1	HEXAGONAL JOINT FOR M10 SCREW

On request, we can provide a longer screw than the standard one.

REF.	PART NUMBER	QTY	DESCRIPTION
3a	2428500	1	SOCKET CAP SCREW M10X70 12.9 UNI5931/DIN912
3b	4180100	1	SOCKET CAP SCREW M10X1.25X60 12.9 UNI5931/DIN912

KIT FOR BLIND THREADED INSERT M12



REF.	PART NUMBER	QTY	DESCRIPTION
1	3441700	1	KIT FOR BLIND THREADED INSERT M12 SOCKET HEAD CAP SCREW

KIT COMPOSITION

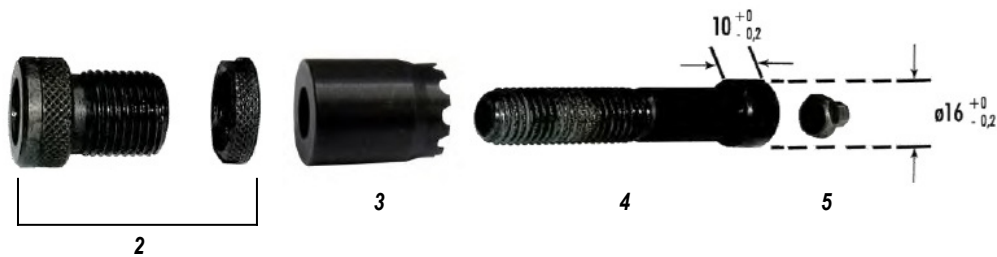

REF.	PART NUMBER	QTY	DESCRIPTION
2	0329100	1	HEAD WITH RING NUT FOR M12 SCREW
3	4316200	1	TOOTHED BLOCKING RING NUT
4	3473300	1	SOCKET CAP SCREW M12X60 12.9 UNI5931/DIN912
5	3473400	1	HEXAGONAL JOINT FOR M12 SCREW

KIT FOR DOUBLE START THREAD INSERT Ø10

REF.	PART NUMBER	QTY	DESCRIPTION
1	4311900	1	KIT FOR DOUBLE START THREAD INSERT Ø10

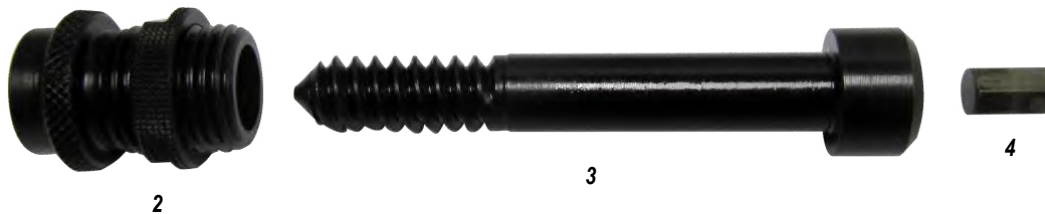
KIT COMPOSITION

REF.	PART NUMBER	QTY	DESCRIPTION
2	0329000	1	HEAD WITH RING NUT FOR M10 SCREW
3	4309700	1	SOCKET CAP SCREW, SPECIAL DOUBLE START THREAD Ø 10X65
4	3472900	1	HEXAGONAL JOINT FOR M8 SCREW

OPTIONAL TOOLING

For Blind Threaded Stud Installation.

NOSE ASSEMBLY PART NUMBERS

Thread Size	Part No. For Complete Stud Nose Assembly
#8-32	4361900
#10-24	4362000
1/4-20	4362100
5/16-18	4362200
M4	3442300
M5	3442400
M6	3442500
M8	3442600



Stud Nose Assembly

Kits are sold separately. A different kit is required for each thread size.

The tool is available with different kinds of head assemblies.



HEAD RING NUT

Can be ordered separately. Part number 0327700.



KIT FOR BLIND THREADED STUD #8-32

REF.	PART NUMBER	QTY	DESCRIPTION
1	4361900	1	KIT FOR BLIND THREADED STUD #8-32

KIT COMPOSITION

REF.	PART NUMBER	QTY	DESCRIPTION
2	2561200	1	HEAD WITH RING NUT FOR #8-32 STUD (HOLE Ø 4.25)
3	4377000	1	TIE ROD FOR #8-32 STUD
4	3441800	1	HEXAGONAL JOINT

KIT FOR BLIND THREADED STUD #10-32



REF.	PART NUMBER	QTY	DESCRIPTION
1	4362000	1	KIT FOR BLIND THREADED STUD #10-32

KIT COMPOSITION



REF.	PART NUMBER	QTY	DESCRIPTION
2	2561300	1	HEAD WITH RING NUT FOR #10-32 STUD (HOLE Ø 5.1)
3	4376700	1	TIE ROD FOR #10-32 STUD
4	3441800	1	HEXAGONAL JOINT

KIT FOR BLIND THREADED STUD 1/4-20

1



REF.	PART NUMBER	QTY	DESCRIPTION
1	4362100	1	KIT FOR BLIND THREADED STUD 1/4-20

KIT COMPOSITION

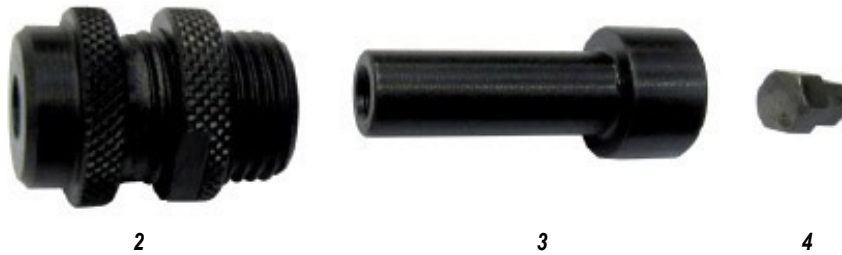

REF.	PART NUMBER	QTY	DESCRIPTION
2	4376800	1	HEAD WITH RING NUT FOR 1/4-20 STUD (HOLE Ø 6.5)
3	4376900	1	TIE ROD FOR 1/4-20 STUD
4	3441800	1	HEXAGONAL JOINT

KIT FOR BLIND THREADED STUD 5/16-18

1



REF.	PART NUMBER	QTY	DESCRIPTION
1	4362200	1	KIT FOR BLIND THREADED STUD 5/16-18

KIT COMPOSITION



2



3



4



5

REF.	PART NUMBER	QTY	DESCRIPTION
2	2700500	1	HEAD WITH RING NUT FOR 5/16-18 STUD (HOLE Ø 8.1)
3	4316200	1	TOOTHED LOCKING RING NUT
4	4376200	1	TIE ROD FOR 5/16-18 STUD
5	3441800	1	HEXAGONAL JOINT

KIT FOR BLIND THREADED STUD M4

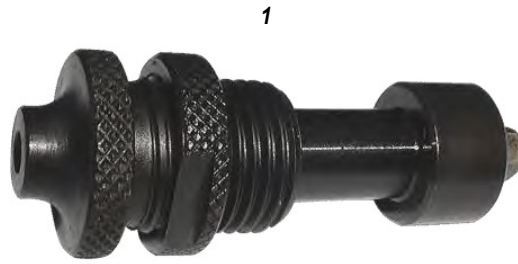

REF.	PART NUMBER	QTY	DESCRIPTION
1	3442300	1	KIT FOR BLIND THREADED STUD M4

KIT COMPOSITION



REF.	PART NUMBER	QTY	DESCRIPTION
2	2561200	1	HEAD WITH RING NUT FOR M4 STUD
3	3441900	1	TIE ROD FOR M4 STUD
4	3441800	1	HEXAGONAL JOINT FOR M4 SOCKET CAP SCREW STUD

KIT FOR BLIND THREADED STUD M5



REF.	PART NUMBER	QTY	DESCRIPTION
1	3442400	1	KIT FOR BLIND THREADED STUD M5

KIT COMPOSITION



REF.	PART NUMBER	QTY	DESCRIPTION
2	2561300	1	HEAD WITH RING NUT FOR M5 STUD
3	3442000	1	TIE ROD FOR M5 STUD
4	3441800	1	HEXAGONAL JOINT FOR M5 SOCKET CAP SCREW STUD

KIT FOR BLIND THREADED STUD M6

REF.	PART NUMBER	QTY	DESCRIPTION
1	3442500	1	KIT FOR BLIND THREADED STUD M6

KIT COMPOSITION

REF.	PART NUMBER	QTY	DESCRIPTION
2	2561400	1	HEAD WITH RING NUT FOR M6 STUD
3	3442100	1	TIE ROD FOR M6 STUD
4	3441800	1	HEXAGONAL JOINT FOR M6 SOCKET CAP SCREW STUD

KIT FOR BLIND THREADED STUD M8

1



REF.	PART NUMBER	QTY	DESCRIPTION
1	3442600	1	KIT FOR BLIND THREADED STUD M8

KIT COMPOSITION



REF.	PART NUMBER	QTY	DESCRIPTION
2	2700500	1	HEAD WITH RING NUT FOR M8 STUD
3	4316200	1	TOOTHED LOCKING RING NUT
4	3442200	1	TIE ROD FOR M8 STUD
5	3441800	1	HEXAGONAL JOINT FOR M8 SOCKET CAP SCREW STUD

SPARE PARTS

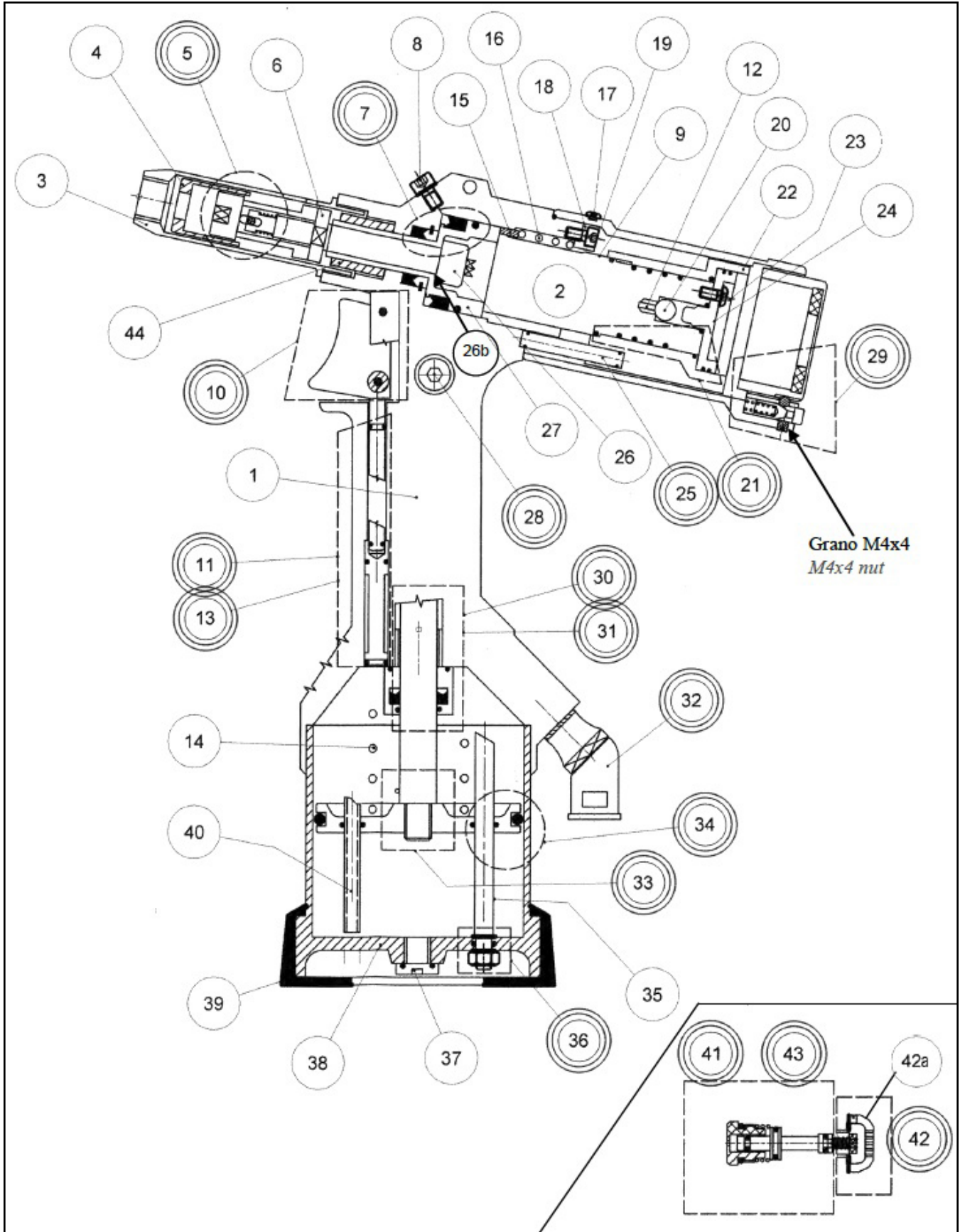

REF.	PART NUMBER	QTY	DESCRIPTION	REF.	PART NUMBER	QTY	DESCRIPTION
1	3542500	1	HANDLE CASING	23	4175300	2	SCREW
2	3540700	1	ENGINE UNIT	24	41761	1	BOTTOM
3	3539900	1	OUTER CONE	25	4175600	1	AIR HOSES KIT WITH O-RING 6 PIECES
4	4172400	1	TOOTHED BLOCKING RING NUT M3-M10	26	4175500	1	ROTATING PIN + SKIMMER
5	4174200	1	QUICK KIT WITH SPRING	26b	3097900	1	SKIMMER WASHER
6	4277200	1	RING NUT (LOCK NUT)	27	4175400	1	OIL PISTON
7	4174300	1	GASKET KIT + SEEGER 4 PIECES	28	4175700	1	OIL CAP KIT WITH O-RING
8	4174400	1	SCREW + WASHER	29	4175800	1	ENGINE PROTECTION KIT 11 PIECES
9	4176500	1	ENGINE CASING	30	4175900	1	WASHER KIT 3 PIECES
10	4174500	1	TRIGGER KIT 5 PIECES	31	4176000	1	COMPLETE STEM GUIDE KIT 4 PIECES
11	4174600	1	KIT WITH O-RINGS 6 PIECES	32	3542900	1	AIR CONNECTION THREAD 1/8" + 1/4" GAS + ALUMINUM WASHER
12	2542200	1	ROD	33	4176200	1	PNEUMATIC PISTON KIT WITH O-RING 6 PIECES
13	4175000	1	O-RING KIT 4 PIECES	34	4176300	1	O-RING KIT 4 PIECES
14	3094100	1	SPRING	35	3543700	2	SCREW
15	4174700	1	SPACER	36	4176400	1	NUTS - WASHERS - O-RING KIT 8 PIECES
16	4174800	1	SPRING	37	3543400	1	CAP WITH O-RING
17	3096400	1	SCREW	38	3543100	1	PNEUMATIC CASING
18	4174900	1	STROKE TOP	39	3543200	1	RUBBER BASE
19	3545600	4	SCREW	40	3543000	1	TRACTION PIPE
20	3096900	1	BALL	41	4191300	1	O-RING KIT 4 PIECES
21	4175100	1	O-RING DISPENSER KIT 9 PIECES	42	4176600	1	BAFFLE KIT 5 PIECES (WITH SPRING)
22	4175200	1	DISTRIBUTOR	43	4176700	1	VALUE UNIT WITH O-RING 7 PIECES
				44	4277300	1	SAFETY RING

You can order separately:

- Deflector ref. 42a (part number 3544000) belonging to kit ref. 42 (part number 4291600).

QUICK KIT COMPLETE WITH SPRING

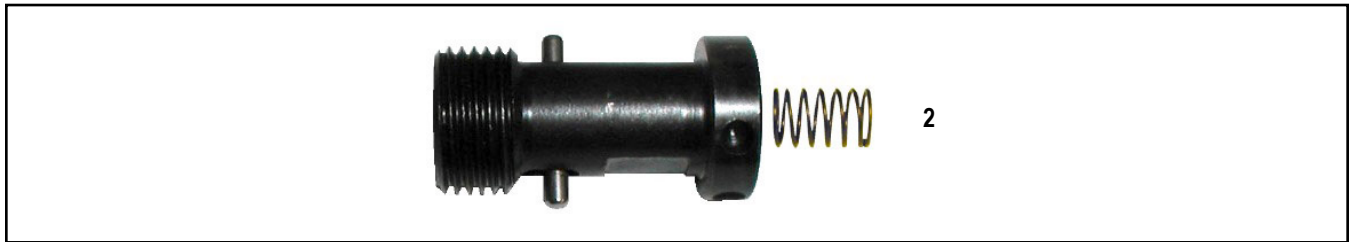
QUICK KIT COMPLETE WITH SPRING WITHOUT TOOTHED RING NUT

TOOTHED RING NUT ASSEMBLED ON THE TOOL

**SPECIAL TOOTHED RING NUT FOR SOCKET CAP SCREW M8
NO NEED FOR REDUCTION (PART NUMBER 3472600) (OPTIONAL)**

REF.	PART NUMBER	QTY	DESCRIPTION
1	4174200	1	QUICK KIT COMPLETE WITH SPRING
2	4176900	1	QUICK KIT WITH SPRING AND WITHOUT TOOTHED RING NUT
3	4172400	1	TOOTHED RING NUT M3 - M10
4	4280300	1	SPECIAL TOOTHED RING NUT, HOLE Ø 8

MOTOR UNIT SPARE PARTS (KIT 2)

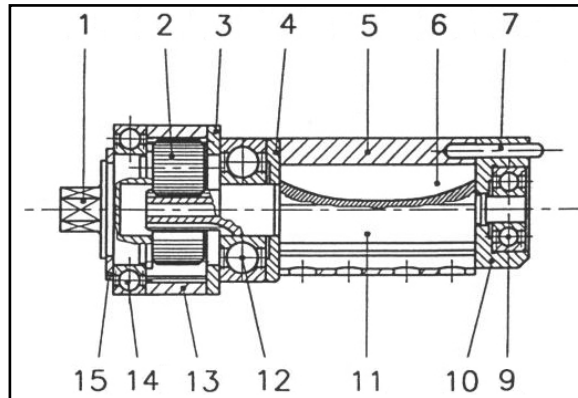
Part number 3540700.



REF.	PART NUMBER	QTY	DESCRIPTION	REF.	PART NUMBER	QTY	DESCRIPTION
1	3240500	1	PLANET WHEEL HOLDER	9	3327300	1	BEARING
2	3238400	3	PLANET WHEEL	10	3327400	1	REAR PLATE
3	3326800	1	SPACER	11	3523400	1	ROTOR
4	3326900	1	FRONT PLATE	12	3327500	1	BEARING
5	3327000	1	STATOR	13	3327600	1	CROWN WHEEL
6	3327100	5	FIN	14	3327700	1	BEARING
7	3327200	1	ROLLER	15	3327800	1	SNAP RING

NOTE: When placing an order, always reference the part number and the description.

RUBBER PROTECTION FOR RIV912 ENGINE

Part number 4091400.



Rubber protection must be removed before tool adjustment.



Adjust the stroke of the tool. If necessary, lock the button after adjustment using the M4 x 4 nut with the 2 mm allen key.



Reassemble the rubber protection.

ORDERING SPARE PARTS

Only local authorized dealers are allowed to repair the tool. Otherwise, contact the ATLAS® Technical Assistance Department of PennEngineering, where qualified engineers can help to solve any problems.

GENERAL WARNINGS

The operator must read carefully the information given in the present manual, especially with regard to the safety precautions listed in this chapter. The operator must also observe the warnings listed below:

- The tool shall be used exclusively by trained personnel.
- The tool and the work area shall be kept clean and tidy.
- The tool shall be rested upright on the rubber base on a flat surface to prevent it from falling.
- The tool shall only be used in normal operating conditions.
- The user shall wear suitable clothing taking care to avoid entanglement of loose parts, ties, long hair, cleaning rags etc. in the tool itself.
- When using the tool, the operator and others nearby should wear safety glasses to protect against fastener ejection. We also recommend wearing gloves when using the tool.
- The user shall use the accessories supplied when servicing and/or adjusting the tool.
- The plates applied on the tool by Rivit S.r.l. shall not be removed or altered.
- Unauthorized personnel shall not be allowed to touch the tool.
- Make sure that the air supply hoses are correctly sized.
- Do not drag the tool holding it by the hose when it is connected to the power supply. Keep the hose away from sources of heat and from sharp objects.
- Remember to remove service or adjustment keys after having making a repair and/or adjustment.
- Before disconnecting the compressed air hose from the tool, ensure it is not pressurized.
- Disconnect the air supply before cleaning or making tool repairs.
- Air supply must be disconnected before making tool repairs and cleaning.
- When filling with oil, only use fluids with the characteristics indicated herein.
- If you should accidentally spill oil on your skin, rinse and wash thoroughly with soap and water.
- Where possible, you are recommended to use a safety balance to support the tool.
- Pay attention to possible risk of whiplash with the air supply hoses.
- Do not operate the tool when it is directed towards anyone.

INTENDED USE

The tool is designed exclusively to be used with female threaded type inserts with thread sizes #4-40 to 1/2" / M3 to M12 and male threaded type studs #8-32 to 5/16" / M4 to M8.

UNINTENDED USE

The tool shall not be used:

- In explosive or aggressive atmosphere or when there is an excessive amount of dust or oil in the air.
- In atmosphere subject to the risk of fire.
- When it is exposed to weather conditions.

RESIDUE RISK

During the normal working cycle and when servicing the tool, the operators are exposed to some residue risks which, due to the nature of the operations to be carried out, cannot be totally eliminated.

It is therefore absolutely crucial not to exceed the maximum pressure indicated in the technical data section on page 5.

IDENTIFICATION/SERIAL NUMBER

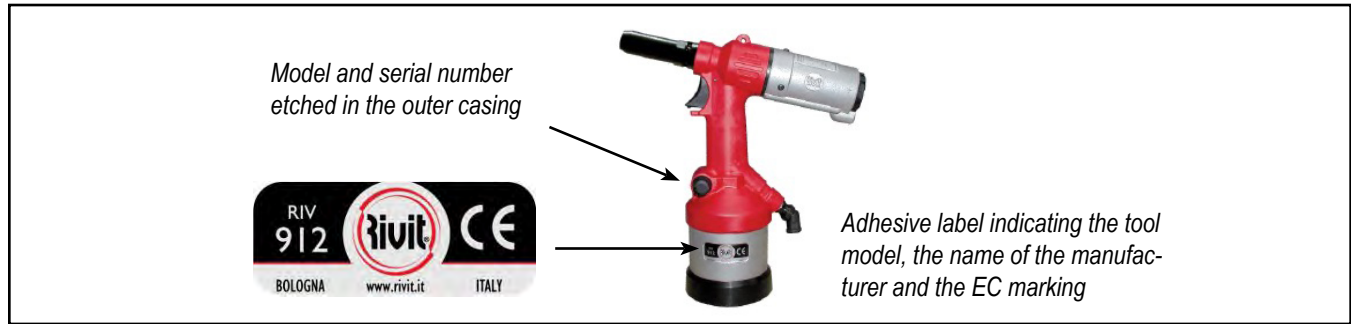

HANDLING

The tool can be hand carried. It is recommended to store the tool in its case after using it. The tool can be transported safely if it has been correctly put away in its case.

Damages to the tool caused during transport and/or handling are not covered by WARRANTY. Repairs or replacements of damaged parts are at Customer's charge.

STORAGE

If you are not going to use the tool for a long time, you must put it away according to the following suggestions:

- Store the tool indoors.
- Protect the tool from impacts and stresses by keeping it in its case.
- Protect the tool from damp and excessive heat.
- Keep the tool away from corrosive substances.

CONNECTIONS

To avoid problems when starting the tool, observe the following:

PNEUMATIC

The pneumatic line is connected by a quick-release coupling hose to be attached to the air connection, thread size 1/4", supplied with the tool. The air supply hose must be flexible and must meet the safety requirements of the tool.

AIR SUPPLY

The air supply line must be free from dirt and moisture to prevent early wear of moving components on the tool. Therefore, it is recommended to use dry air: i.e. not greased.

PRELIMINARY CHECKS

Before putting the tool into service you need to make a few inspections and checks in order to prevent errors or accidents while starting it.

- Check if the tool has been damaged during transportation.
- Check if the compressed air hose is accurately connected to the air supply line.
- Check if the tool turns freely and if the motor runs freely.

OPERATORS

The tool is designed to be used by one operator only.

Tool operators must satisfy the requirements stated hereafter (or they must be informed and trained accordingly). They must be aware of the manual herein and of all information relevant to safety:

- They must have some general and technical education, to a sufficient level to be able to understand the manual and to interpret the drawings and the diagrams correctly.
- They must be acquainted with the safety rules, and with the industrial-safety and technical instructions.
- They must have an overall knowledge of the line and of the factory in which the tool is installed.
- They must know how to act in case of emergency, where to find the individual protection means and how to use them correctly.

Together with the above-mentioned requirements, the service technicians must also have appropriate technical training.

MOTOR SCREWING ROTATES NONSTOP

When the rotating pin (26 part number 4175500) is broken and you replace it, the motor may rotate continuously, which means that the shaft (12 part number 3542200) is too long; in this case it will have to be shortened by a few tenths to obtain the closure of the ball (20 part number 3096900). When the air is on, the shaft shall have no end float.

MOTOR UNSCREWING DOES NOT ROTATE

Unlike the situation above, the shaft is too short and it has to be replaced with a new one, fitting it without end float, with the air on, in order to obtain the closure of the ball (20 part number 3096900).

TOOL PREPARATION AND SCREW REPLACEMENT

The following instructions are indicative, in order to avoid breaking the screw when setting the insert on the tool. You should use a calliper when adjusting the stroke.

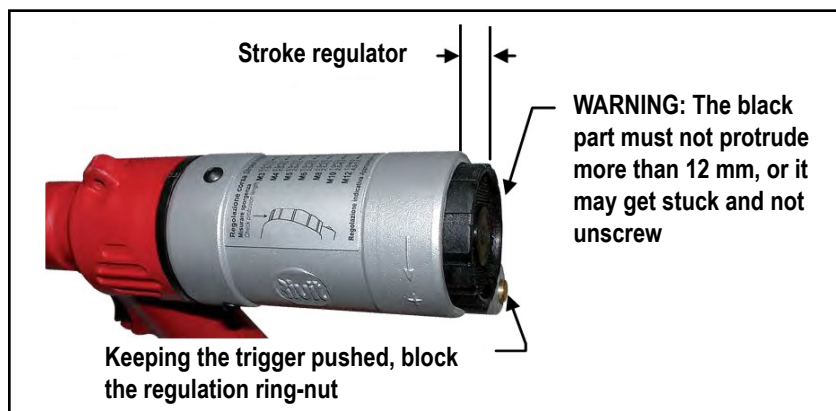

Stroke regulation

Check protrusion length	Approximate regulation
M3 0.5+2.0	7.0 mm
1.5+3.0	7.5 mm
M4 0.5+3.0	6.5 mm
2.0+4.0	7.0 mm
M5 0.5+3.0	7.0 mm
2.0+5.5	7.5 mm
M6 0.5+3.0	7.5 mm
2.0+5.5	9.0 mm
M8 0.5+3.5	8.0 mm
2.5+6.5	8.5 mm
M10 1.0+3.5	8.5 mm
2.5+6.5	9.0 mm
M12 1.0+4.0	11.0 mm
4.0+7.0	9.0 mm

Approximate regulation

Set the tool according to the insert you have to install, and follow the table on the tool.

When the air is connected you can adjust it up to 6.0 mm with a 1.0 mm stroke remaining. If you close the protrusion to 5.0 mm, the stroke will be 0.

SCREW REPLACEMENT

WARNING!!!

Tool setting and screw replacement must be carried out with the tool disconnected from air supply time.

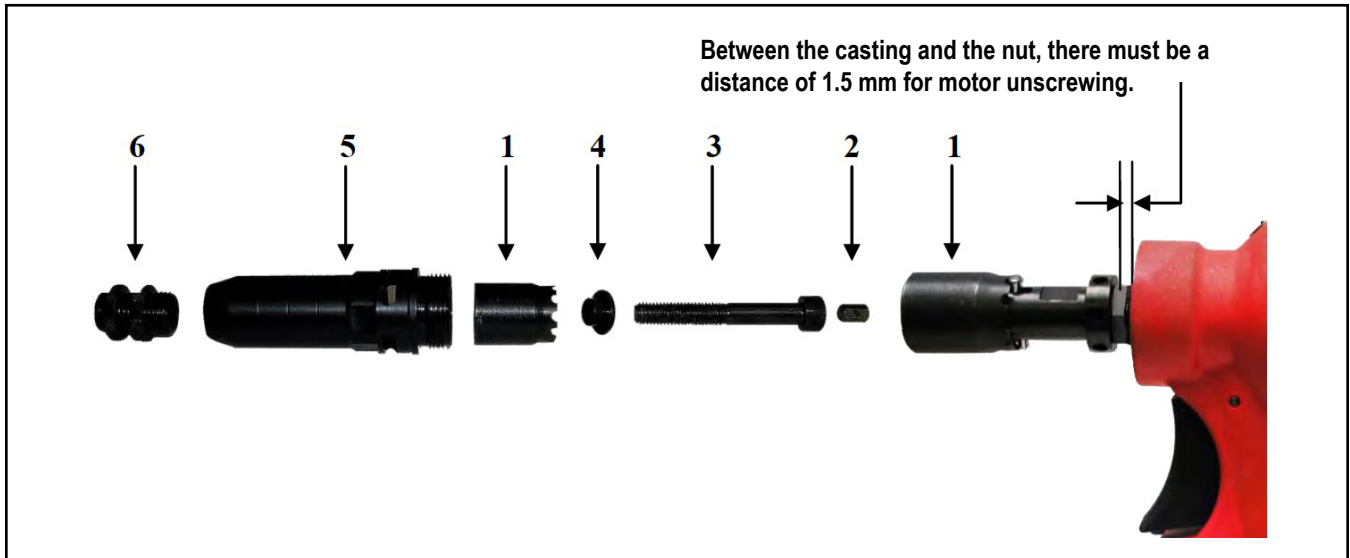

NOTE: Hereunder instructions are relevant to KIT assembling and disassembling.

TO UNSCREW THE KIT HOLDER QUICK RING

Tool setting and screw replacement must be carried out with the tool disconnected from air supply time.

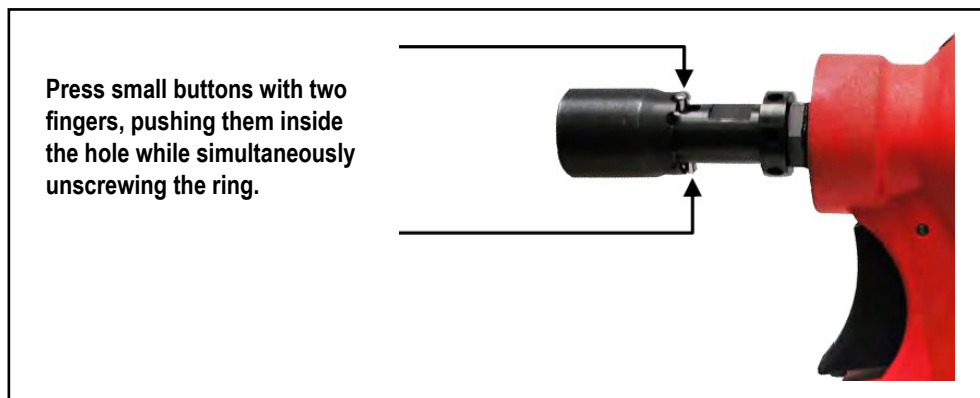

TO REPLACE SCREWS:

Unscrew the toothed ring 1 from the tool. Insert joint 2. Insert screw 3. Insert screw adapter 4. Screw the toothed ring 1 making sure that the screw (or tie rod) rotates, then try and find the most suitable joint (see intended ring). Screw on 5 and 6.

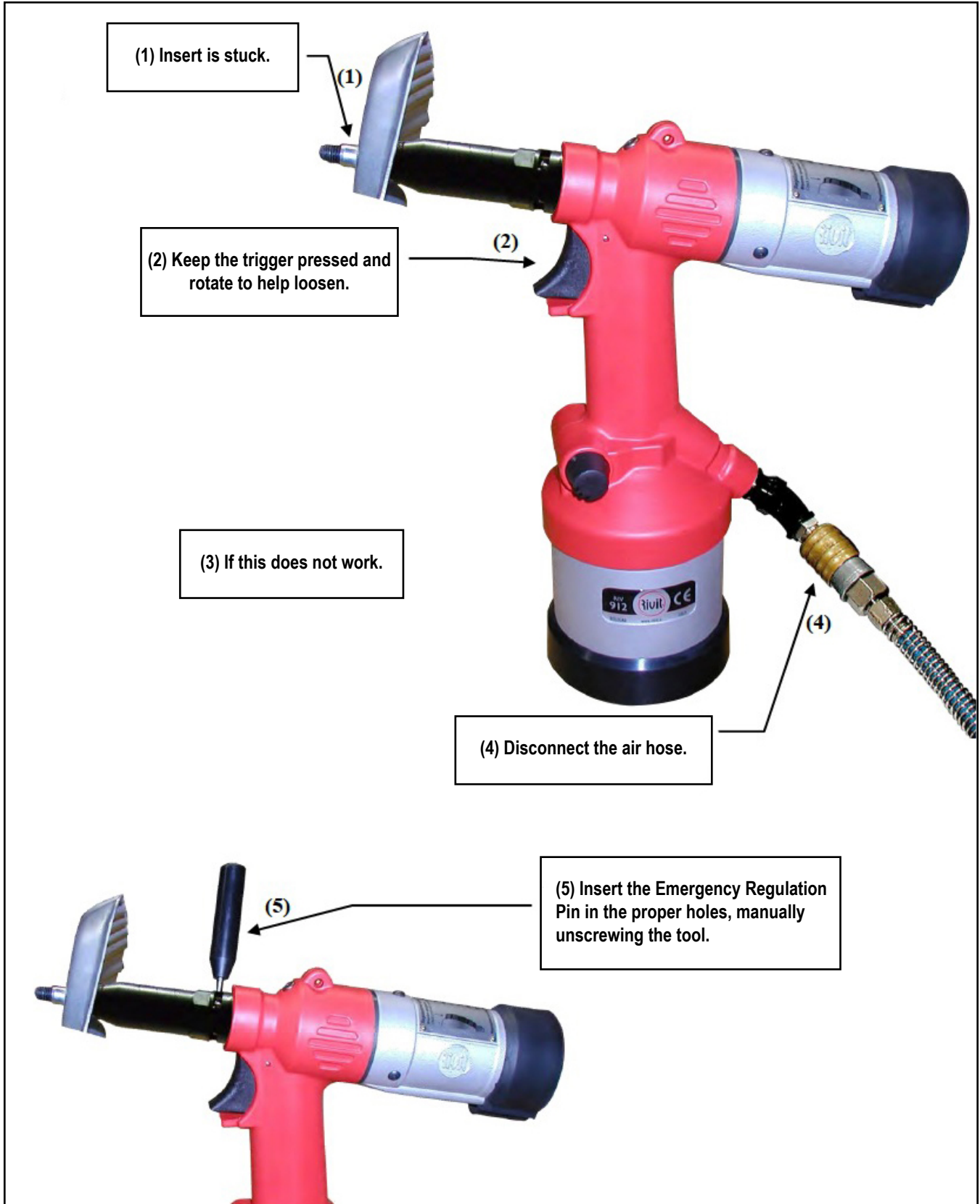

MAINTENANCE

Maintenance operations must be carried out with the tool stopped and disconnected from the pneumatic supply line.

Warnings:

- The tool maintenance instructions must be followed carefully.
- To ensure safety and perfect tool efficiency, it is recommended to use exclusively ORIGINAL spare parts.

CLEANING

It is a good rule to completely clean and grease the tool on a periodic basis (depending on the type and frequency of use). These operations must be carried out at least once a year.

Shut-off all sources of power to the tool.

The operator must wear and use suitable personal protections before starting to clean the tool.

ORDINARY MAINTENANCE

In order to prevent stoppages and faults of the tool, an ordinary maintenance (including inspections, checks and operations) must be scheduled to keep the following under systematic control:

- **State of lubrication of the tool.**
- **State of wear of consumable parts.**

REFILLING THE HYDRAULIC CIRCUIT WITH OIL

The hydraulic circuit needs to be refilled with oil after a continuous use, and when you notice a reduction in the tool stroke.

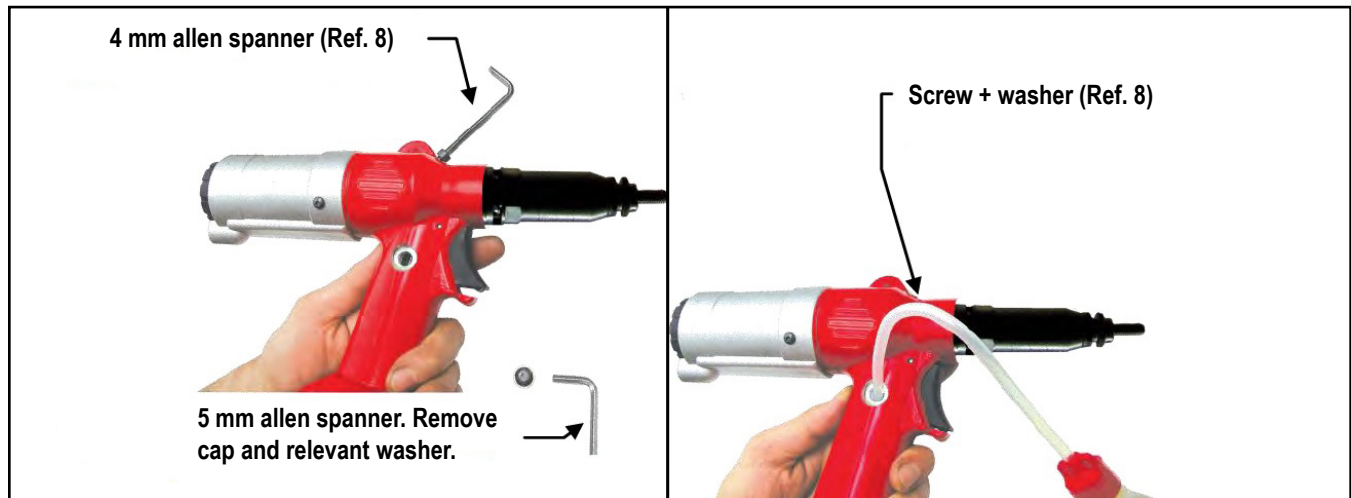

Proceed as follows (see photo above):

- Disconnect the airline from the tool inlet.
- Unscrew cap with relevant washer 27.
- Put the tool in horizontal position and slowly pour in the hydraulic oil (ISO VG 32 type) 84 until the circuit is full.
- Screw cap back on, together with relevant washer 27.
- Connect the tool to compressed air line and start up a couple of idle cycles. Stop pulling the trigger and slowly loosen screw 8 allowing the surplus oil to come out; screw again screw 8 and the tool is ready to be used.

Wear gloves when managing the oil.

Do not throw the old oil outdoors. Hand it over to an authorized waste disposal center.

Warning!: If you should accidentally spill oil on your skin, wash and rinse thoroughly with soap and water.

HOW TO PREPARE, SERVICE AND ASSEMBLE THE TOOL

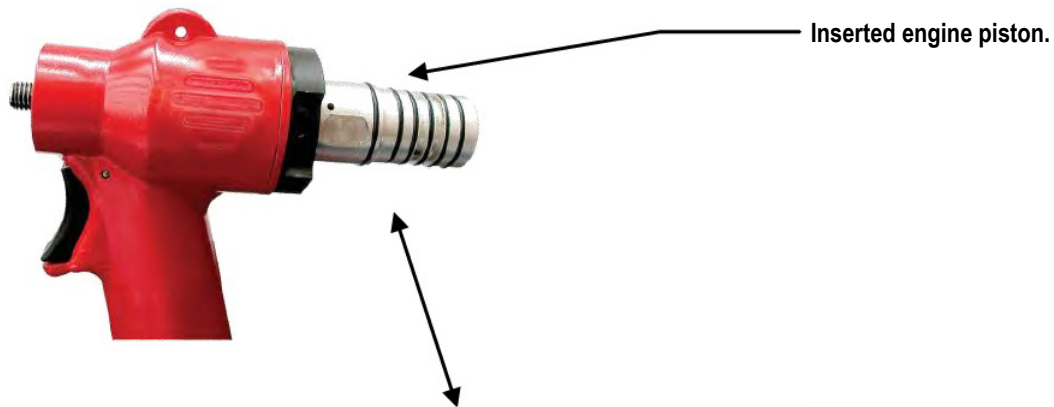



If possible, the air must not be lubricated to keep from removing the grease from the o-rings in the motor piston. To keep the tool in good working condition, we recommend routine maintenance, disassembling and greasing the mentioned pieces with grease for gaskets. The tool work well with dry air.



PARTS SUBJECT TO WEAR

On a periodic basis check the rubber base for wear, as this is what ensures the stability of the tool. If it should need replacing, order the spare base from PennEngineering indicating the year/serial number of the tool.

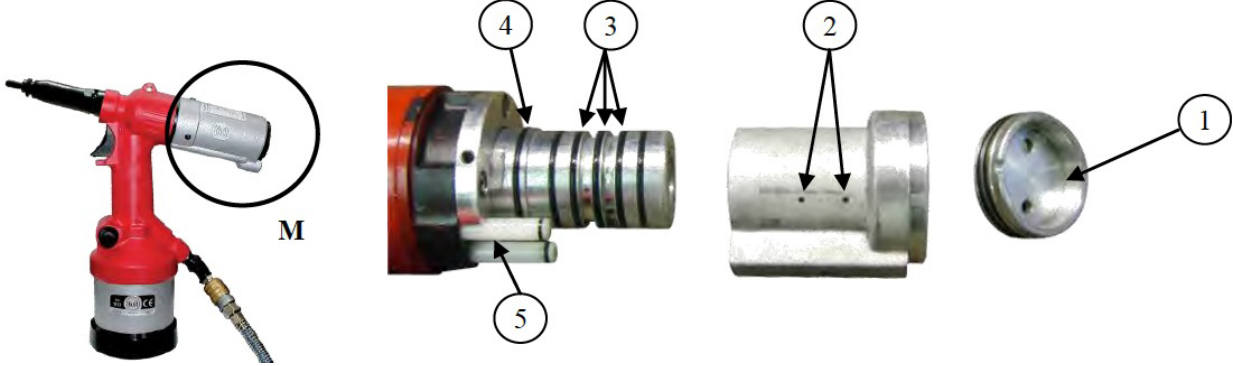
On a periodic basis check the screws and heads for wear and, if necessary, replace them as indicated.

FAULT DIAGNOSIS

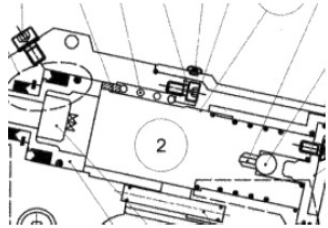
CAUSE	SOLUTION
 <p>No traction.</p>	<p>Tool needs oil.</p> <hr/> <p>Remove the engine cover (M), remove the bottom (1) and check that hole Ø 0.8 is open.</p>
<p>Air leaks from the engine (M), with air on (4) and (3).</p>	<p>Remove the engine cover (M): a substantial leak of air means that o-ring Ø 30 (4) is broken. If only a small quantity of air comes out of the small tubes (5) you have to replace the o-rings.</p> <hr/> <p>If air leaks from the two holes (2) make sure that o-rings are not broken or worn.</p> <hr/> <p>If there are no leaks from the engine (M), you must check the lubrication, greasing the o-rings (3) and (4).</p>
<p>Pressing the trigger you start the piston traction, but the piston return is slower or absent; air leaks from the muffler (6).</p>	 <p>Make sure that you have all the above components, clean the muffler (6) with air, grease and reassemble everything. In case cleaning do does not work, you need to replace the muffler (6). If air still leaks, replace the o-ring (7).</p>

CAUSE	SOLUTION
<p>Motor screwing</p>	<p>When the rotating pin (26 part number 4175500) is broken and you replace it, the motor may rotate continuously, which means that the shaft (12 part number 3542200) is too long; in this case it will have to be shortened by a few tenths to obtain the closure of the ball (20 part number 3096900).</p>  <p>Unlike the situation above, the shaft is too short and it has to be replaced with a new one, fitting it without end float, with the air on, in order to obtain the closure of the ball (20 part number 3096900).</p>
<p>Quick kit assembly</p>	<p>When assembling the quick kit (code 4176900), with air off, make sure to create an axial space of 1.5mm allowing the pin to move freely.</p> 

FAULT DIAGNOSIS AND REPAIRS

REPAIRS

To ensure the operational efficiency and safety of the tool, all repair jobs shall be carried out exclusively by the local authorized dealer or by the Technical Assistance Service of PennEngineering.

REQUESTING ASSISTANCE

For any information concerning Use, Maintenance, Installation, Repair etc., PennEngineering is at the Customer's full disposal for all enquiries.

When making inquiries, the customer is requested to be absolutely clear and to always refer to this Manual.

DISMANTLING INSTRUCTIONS

DISMANTLING INSTRUCTIONS

When disposing the tool you need to separate the plastic parts, which are to be disposed of in compliance with current Regulations.

As for the bulk metal part of the tool, simply split-up the steel parts from those in other metals or alloys and send to be melted down and recycled.

The oil drained from the tool must not be thrown outdoors but handed over to an authorized oil disposal center.

PennEngineering®



North America: Danboro, PA USA • E-mail: atlas@pemnet.com • Tel: +1-215-766-5987 • Fax: +1-215-766-5988 • 877-682-2505 (USA Only)
Europe: Galway, Ireland • E-mail: europe@pemnet.com • Tel: +353-91-751714 • Fax: +353-91-753541
Asia/Pacific: Singapore • E-mail: singapore@pemnet.com • Tel: +65-6-745-0660 • Fax: +65-6-745-2400
Shanghai, China • E-mail: china@pemnet.com • Tel: +86-21-5868-3688 • Fax: +86-21-5868-3988

Visit our PEMNET™ Resource Center at www.pemnet.com